

High strength steels

Graz University of Technology in Austria recently hosted an international conference to share expertise about the design and behaviour of high strength steels utilised in hydropower plant conduits. Richard Greiner, Horst Cerjak and Gerald Zenz give more information.

The third international conference on high strength steels for hydro power plants focused on the design concepts of pressure conduits in September 2013. Initiated by Professor Horst Cerjak and organised in an interdisciplinary way under the chairmanship of the above three authors, it brought together experts from all engineering disciplines of hydro-steel structures and pressure conduit construction – starting with hydraulic engineering, rock mechanics and geology, structural engineering, mechanical engineering up to material science and welding technology. Conference delegates came from hydropower companies, geotechnical and hydropower consultants, hydraulic steelwork suppliers, steel fabricators, steel producers and producers of welding consumables, as well as from universities. Representatives were from European countries, Japan and Africa.

The conference topics comprised planning and construction concepts of pressure conduits (armoured and unarmoured), structural steel design, life cycle evaluation, as well as material quality, welding and quality assurance. This paper highlights just a few selected aspects dealt with during the conference, which might be of interest for practitioners. More information is available in the proceedings* and in the selected papers published in a dedicated issue of the Steel Construction journal**.

High strength

Penstocks of hydropower plants are nowadays usually made of high strength steels (HSS). Diameters of about 12m and more lead to steel structures which are no longer just usual pipes, but are large welded shell structures with cylindrical or conical, possibly ring-stiffened forms in ducts, bends, manifolds or surge tank components (see the example in Figure 1).

Under loading conditions of internal and external pressure with large cyclic and dynamic ranges – resulting from the impact of new service modes and pump storage operation – the structural steel design – on one hand – comprises all possible limit states (ranging from stress design and shake-down to stability and to fatigue design) to be found in existing codes, eg the Eurocodes, for the design of steel and shell structures. On the other hand, the structural behaviour present when there is interaction of the steel liner with the rock mass in underground penstocks leads to design conditions which call for the close collaboration of rock mechanics and geotechnical engineers.

The new high strength steels used in European penstock applications include steel grades with up to 700 MPa yield strength, both quenched

and tempered as well as thermo-mechanically processed ones, while recent applications in Japan go even up to thermo-mechanical grades with 880 MPa yield strength. Plate thicknesses in the range of 100mm or even up to 200mm for sickle plates of branches are in use and demand not only high material quality, but also a high standard of welding technology connected with advanced quality assurance measures. In this regard, these “hydro-steel structures” require close cooperation between many engineering disciplines to guarantee high quality and safe standards.

One main outcome of the conference was the presentation of the international construction standard of pressure conduits of hydropower plants



Figure 1: Erection state of the bifurcator of Limberg II pumped storage project, developed by Verbund Hydro Power AG, Austria (main diameter 7.6m, HSS of grade S550QL)

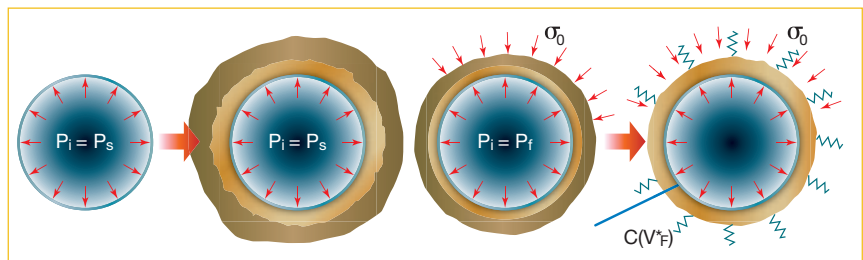

Figure 2: (a) Steel-Penstock (self-supporting), (b) Steel-Lining (rock participation)

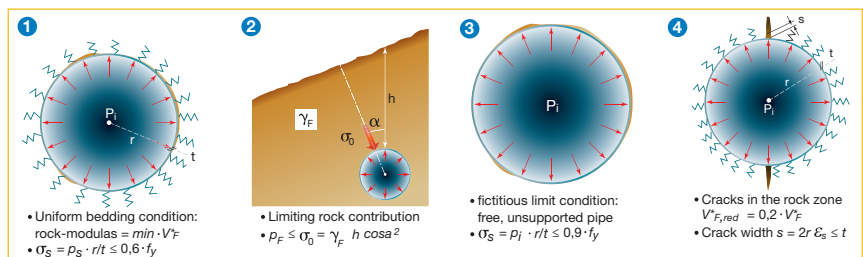

Figure 3: Current design criteria for steel liners under internal pressure (in Austria)

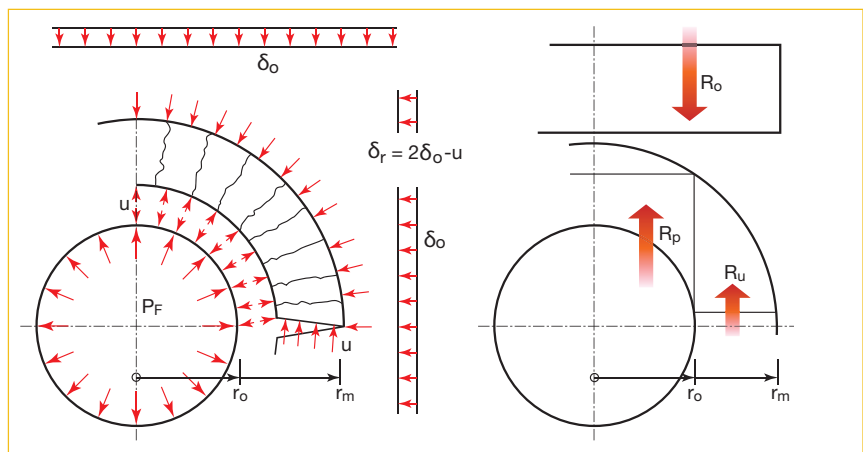

Figure 4: Ultimate limit state of rock with cracked zone: (a) stress state, (b) stress resultants. $R_0 = (2 \delta_0 - u) \cdot r_m$; $R_p = p_r \cdot r_0$; $R_u = u \cdot (r_m - r_0)$

that were just finished, under progress or in the stage of planning. Another outcome was an overview given on new developments of structural design and on recent research results of steel penstocks.

In addition to some general reports on pressure shaft design, a number of interesting projects were presented, which were just finished, are in progress or being planned (see Table 1).

Structural behaviour of steel liners

The basic design principle of underground penstocks is the assumption of whether the steel pipe is interacting with the rock mass or not. Both approaches may be found (even in current international projects), i.e. the design as self-supporting pipe embedded in the rock (Figure 2a) or the design as lining closely interacting with the surrounding rock mass (Figure 2b).

From their mechanical background the first develops from the idea of a free penstock transferring just its weight to the rock, while the second starts with the structural behaviour of an unarmoured conduit utilizing the steel lining either just for reasons of sealing the conduit or to carry part of the internal pressure. In this case – like for the unarmoured conduit – the primary stress state σ_0 in the rock mass plays an important role.

From the point of view of erection and construction, the two approaches have much in common, such as similar concrete backfilling around the steel pipe or contact grouting for reasons of outside corrosion protection etc. However, the second approach usually applies substantial injection measures into the rock formation aiming at homogenizing the rock mass and equalizing its stiffness. Such measures require injection nipples in the lining which – considering the fatigue life of the conduit – may form weak spots due to their pronounced notch effects.

The current structural design of linings with rock participation tries to capture the complex mechanical effects by a number of isolated design criteria (Figure 3). Criterion 1 describes the well-known interaction of steel liner, concrete and rock under the internal pressure p_i and criterion 2 roughly represents the primary stress state in the rock mass. Criterion 3 represents a fictitious safety check for the pipe without any rock support, while criterion 4 provides a ductility check for the liner in case of cracks along the rock surface.

Reconsidering the four criteria makes it clear

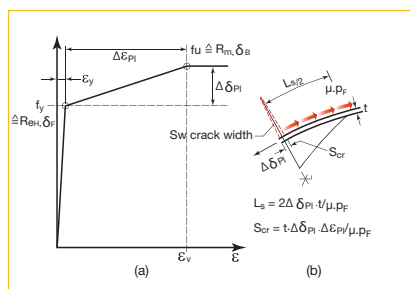

Figure 5: crack-bridging: (a) linearized material behavior (b) critical crack-width S_{cr}

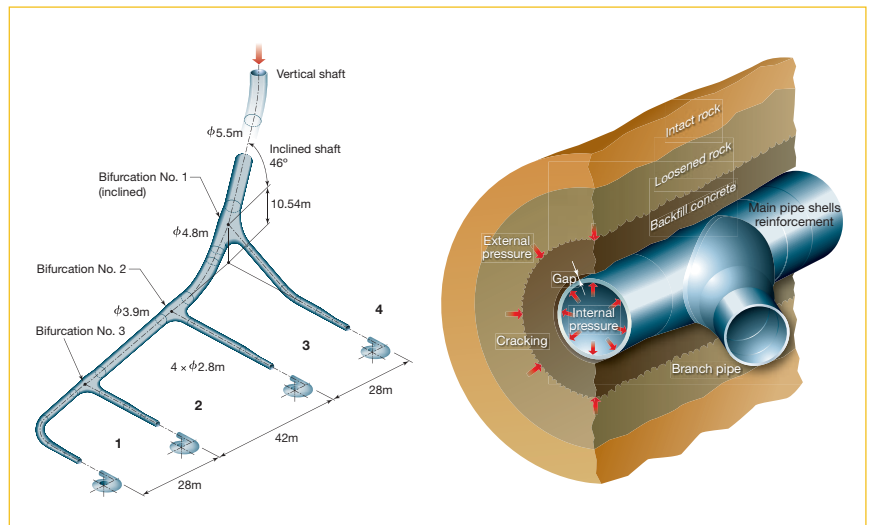

Figure 6: Okumino manifold (units 1-4) and model of the rock-embedded model [3]

that they act like isolated corner posts marking a field within which the right solution should be found, rather than defining mechanically consistent limit states. In a consistent safety concept – e.g. as given by the Eurocode-concept - clear distinctions are made between the ultimate limit state ULS (increased load level $\gamma_f \cdot p_i$) and the serviceability limit state SLS (service load level p_i). While criterion 1 represents a consistent SLS-limit state on basis of an allowable stress level, the real safety level of the ULS-limit state remains open. An advanced design concept would therefore be needed.

Innerhofer's approach

An advanced approach was presented at the conference in [1] and [2]. The main progress of this concept results from the new continuous description of the mechanical behaviour of the rock mass around a sealed (unarmoured or armoured) pressure shaft. The idea and derivation of this concept is to be credited to the work of Guntram Innerhofer, sen. It consists in the equilibrium state of the rock mass after a radial crack opens and grows to a certain depth r_m . Thereby, the effect of the crack water pressure u becomes active. The draft in Figure 4 illustrates the equilibrium of the rock mass in the primary stress state σ_0 when loaded by the pressure p_f in the conduit. Under increasing pressure p_f the fractured zone (r_m-r_0) propagates as long as equilibrium is found with the primary stress state σ_0 and the crack-water pressure u . Outside the boundary r_m sound rock exists. Provided that the stress state may be considered as uniform about the circumference, confinement is found as long as $(\sigma_r = 2\sigma_0 - u)$ is not exceeded. As resultants, the equilibrium condition can be set up by the components R_{θ} , R_p and R_u . R_{θ} represents the capacity of the rock mass along the boundary r_m . R_p is the resultant of the part p_f of the internal pressure. R_u denotes the effect of the crack water pressure acting along the depth of the crack. As result of the equilibrium, one may find expressions for the crack depth under a given pressure p_f or for p_f under a given crack ratio r_m/r_0 :

$$\frac{r_m}{r_0} = \frac{P_f - u}{2(\sigma_0 - u)} \quad \text{or} \quad P_f = 2(\sigma_0 - u) \frac{r_m}{r_0} + u$$

It may be noted that conservatively no strength effect of the rock mass has been included and that the results are independent of the stiffness of the rock V_f^* . The rock would be free of cracks up to pressures $p_f = (2\sigma_0 - u)$, i.e. that the rock is confined up to $r_m/r_0 = 1,0$ (in contrary to the current criterion 4 above). Particular regard should be paid to the primary stress σ_0 which becomes the governing parameter of the design and needs sound experience of geotechnical experts, since its magnitude is not only determined by the height of the overburden above the pressure shaft but it may as well be influenced by previous tectonic events and local conditions of the ground surface.

The derivations also comprise the expressions for the radial deflections of the rock consisting of two parts, i.e. that of the fractured zone (r_m-r_0) in radial compression and that of the sound zone (outside of r_m) in circumferential tension. The interaction between the rock mass and the steel liner can, therefore, be well determined.

The second use of the radial deflection is to calculate the potential width of the crack S_w . Because of the composite behavior of liner and rock – both are circumferentially bonded by the effect of friction under the contact pressure p_f – the opening of a crack must be bridged by the liner steel plate in a localized area over the length L_s (see Figure 5b). This enforced elongation requires adequate ductility of the steel and may be approximated by the plastic parameters $\Delta\epsilon_{pi}$ and $\Delta\sigma_{pi}$ of the material behavior. Assuming linearized stress-strain behavior as illustrated in Figure 5a, the stretched length L_s and the critical crack-width S_{cr} may be determined by the formulae given in the figure (μ ... friction factor). The above expressions underline the high significance of strain hardening $\Delta\sigma_{pi}$ and of the elongation $\Delta\epsilon_{pi}$ (ultimate strain ϵ_y) of the material and the ability of the wall to evenly elongate over the length L_s . This means that – given the case that the longitudinal weld was in the stretched area – overmatching of

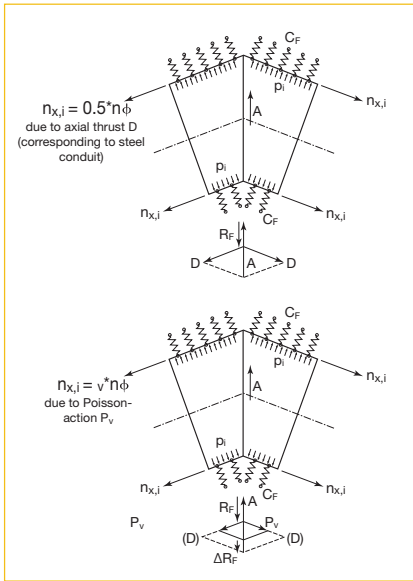

Figure 7: Rock-embedded miter bends under internal pressure with axial thrust or Poisson forces [4]

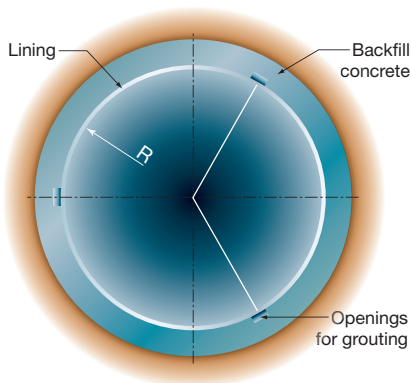

Figure 8: Section of steel-lined pressure shaft (left), outside/inside view of welded nipple (right)

the weld would be significant in order to avoid the concentration of the elongation in the weld area. The limited potential of modern HSS to provide sufficient ductility and the results of undermatched welds are

Table 2: Overview on Construction Details and Design Fatigue Resistances/Proposal

Construction Detail	Wohler-Strength		
	Bore hole	Thread	Weld
	$\Delta\sigma_R$ [N/mm ²] ₁		$\Delta\sigma_R$ [N/mm ²] ₂
AHP N1 N2	365	260	125 (outside weld not ground)
			160 (all welds ground flush)
TIW	365	260	110
VIW		240	
N3	-	340	-
ZUS	390	340	-
Bohrbl. Drilled hole D = 30mm (deburred)		-	-
1), 2) ... correction factor for wall thicknesses larger than t = 22mm	$k_s = \left(\frac{25}{t}\right)^{0,1}$		$k_s = \left(\frac{25}{t}\right)^{0,2 \text{ resp } 0,1}$

discussed in [2]. Practical examples show that the new approach merges the different design criteria of rock mass and liner in a mechanically consistent way, that it allows a transparent assessment of the material behavior of HSS and that in many cases it tends to a reduction in the amount of steel used. In addition, an overview is given in [2] of studies on the effects of non-uniform rock stiffness V_F^* along the circumference of the liner. Analogous studies on non-uniform primary stress states of σ_0 are in progress.

Rock participation

The design of special parts of linings as branch pipes and miter bends under internal pressure is usually based on the assumption of self-supporting conditions. Advanced developments for rock participation were presented in [3] and [4].

In the Hongawa Power Plant in Japan, the rock-embedded bifurcator with diameters 4.7/3.5m – designed without rock participation – was used to study the interaction with the rock mass by in situ stress measurements and by FE-calculations of the rock-embedded model

[3]. The good agreement of the two justified the utilization of rock-interaction at the manifolds of the large Okumino Power Plant (1.5GW) with main diameters 5.5m and three bifurcations in HSS (Figure 6). Again, measurements and FE-calculations well confirmed the participation of the rock, which reached a benefit of about 20%. For the design of rock-embedded miter bends, design formulae have been derived by analytical studies and comparative numerical calculations [4]. Thereby, the effects of the specific axial forces acting in underground installations play an important role (Figure 7). The analytical formulae coincide with the well-known design formulae for exposed bends in the case when the bedding was neglected. The benefits of the new design tools are – aside from the more economical design – mainly an improved calculation of secondary stresses and of the stress concentrations at the miters for fatigue checks.

Fatigue design of HSS linings

Owing to the increased use of HSS in hydro plants, a research project of the Austrian Research Agency

Table 1: Projects presented

Type	Status of Work	Name of Plant	Country	Max. diameter [m]	Design Pressure [mwc]
Liner	in operation	Limberg II	Austria	4,8	670
Liner	finalizing	Reisseck II	Austria	3,6	1050
Liner	starting	Obervermunt II	Austria	4,5	495
Liner	in progress	Kaunertal	Austria	4,3	1007
Liner	in operation	Hongawa	Japan	6 - 4,7	567
Liner	in operation	Okumino	Japan	5,5	770
Penstock	in progress	Teles Pires	Brasil	12	53
Inlet Liner	finalizing	Picote II	Portugal	10,7	115
Branch Pipe	project basis	Nant de Drance	Switzerland	7,0	525
Branch Pipe	project basis	Grimsel 3	Switzerland	6,0	650
Liner	project basis	Atdorf	Germany	4,8	760
Liner	in progress	Linthal 2015	Switzerland	4,4	785
Liner	in progress	Innertkirchen 1	Switzerland	2,4	670

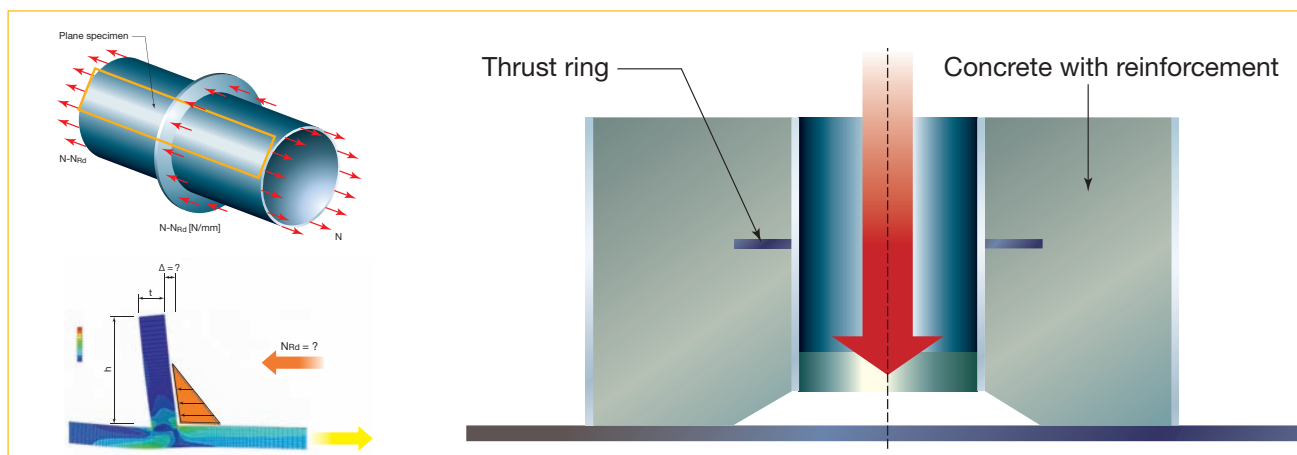

Figure 9: General models for testing – plane specimen (left) and cylindrical test arrangement (right)

FFG was conducted aiming at the fatigue design of linings with grouting nipples (Figure 8) in HSS-grades 700 (Q and TM), since under the new dynamic conditions of hydropower plants the then existing rules for nipples usually dominated the design.

The report given in [5] presents the experimental and numerical research and the statistical derivation of Woehler-lines (SN-curves) for the specific nipple-shapes used in practical applications. A total of 35 fatigue tests (with welded and drilled nipples) were carried out with HSS-specimens of overall dimensions 280x840mm and 15mm plate thickness. Numerical simulations were made for reasons of evaluation as well as for determining the stress concentration factors for the specific types of nipples. Just the final results of the development are presented in Table 2. Concerning this data, it must be noted that the SN-curves are based on the structural hot spot stress concept, the fatigue strength $\Delta\sigma_R$ is related to 2×10^6 cycles and to HSS of grade 700 and the slope is $m=5$. The stress range $\Delta\sigma_s$ in the design equation (equation 2) is determined by the nominal stress times the stress concentration factor SCF of the nipple times the shape factor α_{Koll} of the load spectrum (determined without cut off limit). The safety factor $\gamma_t = 1,35$ is recommended, provided fabrication quality corresponds to the standard defined in the project.

$$\alpha_{Koll(m/2.10^6)} \Delta\sigma_{s,max} \leq \frac{\Delta\sigma_{R(m/2.10^6)}}{\gamma_f}$$

and

$$\Delta\sigma_{s,max} = \Delta\sigma_{nom} \times SCF$$

The outcome of the project are design tools based on experimental evidence which fulfill the requirements of modern limit state design and allow for an amended assessment of fatigue life of pressure shaft. Further information on research in progress on the fatigue strength of steel penstocks was presented in [6].

Thrust ring research

The experimental and numerical research on the load carrying behavior of thrust rings (or anchor rings, see Figure 9a) made of steel plates – funded

by the Austrian Research Agency FFG – was reported in [7]. Eight tests with planar specimens and two tests with cylindrical pipes (Figure 9b) were carried out and numerically analyzed. The main focus was finding the distribution and magnitude of the (triaxial) concrete pressure and the axial ductility of the thrust ring in the concrete – all in connection with the development of a FE-software for further simulations, which finally should lead to a design model for thrust rings. The outcome of the research was – firstly – that the maximum concrete pressure at the thrust ring was considerably higher than usually applied in current design and – secondly – that the ductility of the thrust ring was much higher than expected and could be well simulated by the adapted program. The work in progress should, therefore, lead to a much improved design procedure as a result.

An overview on the development of steel grades for hydro conduits in the last 50 years was presented in [8]. It illustrates the development from quenched and tempered steels (Q+T) to thermo-mechanically

treated steels (TM). The first application of TM heavy steel plates of grade 700 for liners in Austria at the PSP Reisseck II and the results of the qualification program was reported in [9]. A similar report [10] illustrates the procedure of material testing, of pilot testing of welding and of its quality control for the HPP Kaunertal (Austria) where the TM steel grade 580/820 has been selected. Highly interesting insight into the development of heavy steel plates for penstocks was given for grades up to TM-HT960 (yield 880 MPa) by Nippon Steel in Japan [11] and for grades up to 700 (yield) by voestalpine in Austria [12]. ■

Author information

Em.Univ.Prof Dr. Horst Cerjak, Institute for Material Science and Welding; Em. Univ.Prof. Dr. Richard Greiner, Institute of Steel Structures; Univ.Prof. Dr. Gerald Zenz, Institute of Hydraulic Engineering and Water Resources Management, Graz University of Technology, Austria.

References

- [1] Innerhofer, G. sen. and Innerhofer, G. jun.: Considerations on concepts for the design of pressure shafts.
- [2] Greiner, R., Innerhofer, G. sen. and Sterling, W.: New design aspects for steel linings of pressure shafts made of high strength steel.
- [3] Takeyama, M. and Murayama, H.: Reduction in stresses in penstock bifurcations.
- [4] Lechner, A., Greiner, R. and Krueger, K.: Stress analysis in rock embedded miter bends – new derivation and extension of existing formulae for the use in penstocks.
- [5] Greiner, R. and Lechner, A.: Fatigue strength of high strength steel-linings with different types of grouting openings.
- [6] Demal, R. and Moser, C.: Fatigue assessment of hydro power plants-penstocks using IIW-notch concept.
- [7] Unterweger, H., Ecker, A. and Sterling, W.: Load carrying behavior of thrust rings in pressure conduits.
- [8] Cerjak, H., Enzinger, N. and Pudar, M.: Development, experience and qualification

- of steel grades for hydro power conduits.
- [9] Mayrhofer, J., Kirilowitsch, C., Cejak, H. and Enzinger, N.: Qualification procedure of thermo-mechanical steel ALFORM 700 for pressure shaft lining of Reisseck II pumped storage HPP.
- [10] Hammer, A., Schueller, O., Maldet, R. and Bonapace P.: The renewal of the pressure shaft for the high head hydro-power plant Kaunertal in Austria – part 2.
- [11] Onishi, K., Okushima, M., Kurebayashi, K., Katsumoto, H., Kamo, T., Kawabata, T. and Fujiwara, K.: Application of TMCP to high tensile strength steel plates for penstocks.
- [12] Egger, R., Kapl, S. and Mayrhofer, F.: High strength heavy plates for penstocks.

*The Proceedings of the Conference are available at www.ub.tugraz.at/Verlag with the ISBN 978-3-85125-292-7

** Selected papers of the conference were published in the Journal Steel Construction-Design and Research, Volume 6, November 2013, ISSN 1867-0520(print) and ISSN 1867-0539(online).