

COMMISSION  
INTERNATIONALE  
DES GRANDS BARRAGES  
-----  
VINGT-QUATRIÈME CONGRÈS  
DES GRANDS BARRAGES  
*KYOTO, JUIN 2012*  
-----

**Question 93**  
**SAFETY**



Gerald ZENZ  
Graz University of Technology  
Hydraulic Engineering and Water Resources Management  
AUSTRIA

General Reporter

TABLE of CONTENTS

1	Introduction.....	3
2	Reports presented.....	4
3	Related Previous activities on safety.....	5
4	Safety .....	7
4.1	Introductory Statement.....	7
4.2	Structural Safety .....	8
4.3	Risk Assessment .....	11
4.4	Public Safety .....	13
4.5	Risk Management.....	14
4.6	Education and Capacity Building .....	16
5	Contributions .....	18
5.1	Accidents and incidents in dams and reservoirs – Recent case studies	18
5.2	Risks associated with human and organizational factors .....	21
5.3	Regulatory concepts, guidelines and good practice .....	22
5.4	Specific Risks for small dams .....	24
5.5	Risks specific to tailing dams, pump-storage schemes, flood control structures and other special purpose dams.....	25
5.5.1	Education and capacity building.....	27
6	conclusions.....	28
	Acknowledgements.....	29
	REFERENCES.....	29

## 1 INTRODUCTION

“Safety” is perceived from the public as a valuable high achievement. The level of safety is very dependent on individual and social factors. The aim in general should be an utmost feasible high safety standard. This is valid for the society, their living standard and the available infrastructure as e.g. traffic, bridges, and houses.

An appropriate established way to account for “safety” as such is to carry out risk assessment investigations based on hazard identification, in order to evaluate the vulnerability, and to find a measure to account for risk. With the aim to reduce losses due to hazards, risk management methods are developed and applied. However, for our activities in society a quite broad diversity about the fact “which risk to be tolerated” exists. Individual risks taken have to be seen differently from risks to a part or the entire society.

Basically we do have the abilities and instruments at our hands to carry out risk assessment. For example, it is common to carry out flood investigations based on hydrological forecasts. For a return period of the flood event protection measures are designed. The design and decision about the construction of protection buildings is based nowadays on a loss benefit analysis. However, sometimes these decisions are politically overruled. In addition to structural measures managerial aspects are to be considered to reduce risk. For different construction sites different levels of risks are accepted. However, for the equilibrated and fair development in society the risk level should approximate. No general rule exists at the moment about the acceptable risk, but several communities are preparing to define their level of accepted risk.

Safety is in a more general sense the overall description for the process of risk assessment with the additional individual impression of an actual situation.

Based on the terrible disasters from Tohoku earthquake in Japan in 2011, the safety of Nuclear Power in Europe especially in Germany was suddenly questionable and resulted in a shutdown of nuclear plants without any rational argumentation related to the earthquake event. It was “only” a general concern about “safety”. From this impression one might argue the waste of social capital of a society, which could have been prevented by means of public involvement based on better developed democratic procedures. Therefore it is essential for a society to first clearly identify and communicate the sources of hazards. Based on these findings a more rational approach to reduce the risk could be achieved.

Our ICOLD dam community contributes to reduce the risk and to increase the safety of dams, though we always have to bear in mind that dams – small as well as large dam structures – entail a certain amount of risk

Essential for the process to achieve safety is the open minded communication within our groups of experts, for which this Question Q-93 about Safety could be taken and our continuous, successful undertaking of education to all members in our small, global world.

## 2 REPORTS PRESENTED

The question Q93 – Safety – is divided into the following sub-themes for the contributions:

1. Accidents and incidents in dams and reservoirs – Recent case studies
2. Risks associated with human and organizational factors
3. Regulatory concepts, guidelines and good practice
4. Specific risks for small dams
5. Risks specific to tailing dams, pump-storage schemes, flood control structures and other special purpose dams

The international community responded with 44 contributions to question Q93 - Safety. Most of the contributions are coming from the National Committee of Spain (7), followed by Japan (6), France (5) and from China and South Africa each with (4). The general participation is shown in the following Table 1 and Figure 1.

Contributions (44)	National Committees(16)
7	Spain
6	Japan
5	France
4	China, South Africa
3	Switzerland, Romania, Russia
2	United States
1	Austria, Czech Republic, Indonesia, Mozambique, Sri Lanka, Sweden, Poland

Table 1: Participation to Q93 by National Committees

Despite the fact that many contributions are devoted to and with a special focus on one of the sub-themes, many in fact relate to other aspects not covered by the sub-themes.

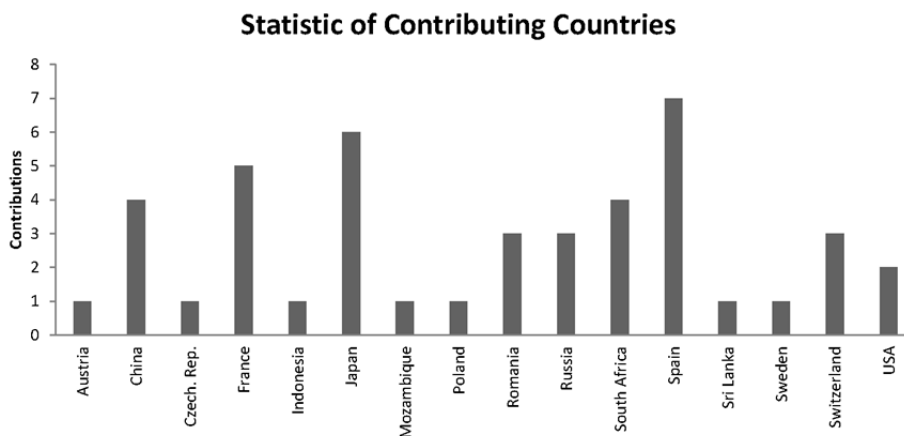

Figure 1: Graphical distribution of Contributing Countries

### 3 RELATED PREVIOUS ACTIVITIES ON SAFETY

As Safety is a major concern in our community many Bulletins as well as previous questions to topics at conferences referred to this essential aspect. From the list of Bulletins available the ones directly referring to Safety are summarized in Table 2.

Nr	Title	Year
139	Tailings Dams Safety	2006
130	Risk Assessment in Dam Safety Management	2005
121	Tailings dams risk of dangerous occurrences	2001
109	Dams less than 30m high – Cost Savings and Safety Improvements	1998
99	Dam Failures – Statistical Analysis	1995
E02	Nonstructural Risk Reduction Measures	2001

Table 2: Available ICOLD Bulletins related to Safety of Dams

Further, many questions resulted in contributions about safety during earlier ICOLD conferences and are summarized in Table 3.

Question	Title	Conference
91	Dam Safety Management	23 <sup>rd</sup> Brasilia - 2009
86	Safety of earth and rockfill dams	22 <sup>nd</sup> Barcelona - 2006
85	Management of the downstream impacts of dam operation	22 <sup>nd</sup> Barcelona - 2006
83	Seismic aspects of dams	21 <sup>st</sup> Montreal - 2003
79	Gated spillways and other controlled release facilities and dam safety	20 <sup>th</sup> Beijing - 2000
78	Monitoring of dams and their foundations	20 <sup>th</sup> Beijing - 2000
76	The use of risk analysis to support dam safety decisions and management	20 <sup>th</sup> Beijing - 2000
75	Incidence and failures of dams	19 <sup>th</sup> Florence - 1997
68	Safety assessment and improvement of existing dams	18 <sup>th</sup> Durban - 1994

Table 3: Previous Questions related to Safety of Dams

Question 91 (23<sup>rd</sup> Congress - Brasilia) with the title “Dam Safety Management” is clearly related to the topic. The sub questions are risk assessment methods, regulatory and economic issues, impacts on the operation of reservoirs, emergency plans and communications and finally aspects about remote monitoring and control of dams. Apart from the technical aspects the communication to and the involvement of the public is highlighted, as risk and uncertainty are key aspects of engineering activities. However, the decision about the officially accepted level of safety should not be an engineering issue alone but mainly a political one. Therefore a more transparent communication is called

for in order to arrive at sound and responsible policy choices. However, we have still got a long way of education to improve public perception and enhance responsible participation to go.

Question 86 (22<sup>nd</sup> Congress in Barcelona 2006) relates with “Safety of earth and rockfill dams”, with its subtopics on safety classification, risk assessment, prevention against overtopping, breach formation and seepage measures. The necessity underlined to carry out classification depending on countries and regions, to better reflect the local value and rate of acceptance. The update of hydrological data is seen as essential for safely passing high water flow. The main risk identified for fill dams is uncontrolled overflow and therefore requires the need for rehabilitation. This causes major problems in developing countries to meet international standards.

Question 76 (20<sup>th</sup> Congress in Beijing 2000) relates with reports of “The use of risk analysis to support dam safety decisions and management”. This was the first contribution to a question subject about the various matters of risks, as a combination of judgment and science. Risk assessment is intended to help create a basis for unbiased decisions and is a valuable aid for dam safety, as is the involvement of public into the aspects of safety.

Additionally, the ICOLD working groups are contributing valuably to the state of the art in dam engineering through their discussions, contributions to conferences, and publishing their work in Bulletins. Most of the committees are contributing to safety aspects. For example, the Committee on Dam Safety has on its agenda as term of references to prepare tools to aid on dam risk management [2]. It is intended to include methods for analyzing mechanisms of dam failures and incidences and account for organizational arrangements for risk reduction. In addition the current status of dam safety legislation and regulations in ICOLD member countries are to be reviewed and public safety aspects are considered too. This ongoing work will contribute valuably to increase dams’ safety, discuss these issues in our world-wide community, and to increase and keep the awareness high.

4 SAFETY

4.1 INTRODUCTORY STATEMENT

Safety seen “traditionally” is based on a rational approach but safety has a significant mental social aspect which accounts for safety and the perception of safety in society. What finally makes the difference will not be considered herein in too much detail; we’ll try to keep the focus on the rational approach and leave the mental one for the social - political scene.

Safety for the society is of course one of the main reasons to keep the dams safe and to prevent dam failures but there are other kind of hazards too to the public which are not directly related to structural dam safety. As discussed in Bowles [10] the underlying legal concept in a society plays an essential role in the approach to achieve a tolerable risk level and can be represented e.g. Figure 2 from [12]. From the engineering point of view, the results achieved in the end should be the same

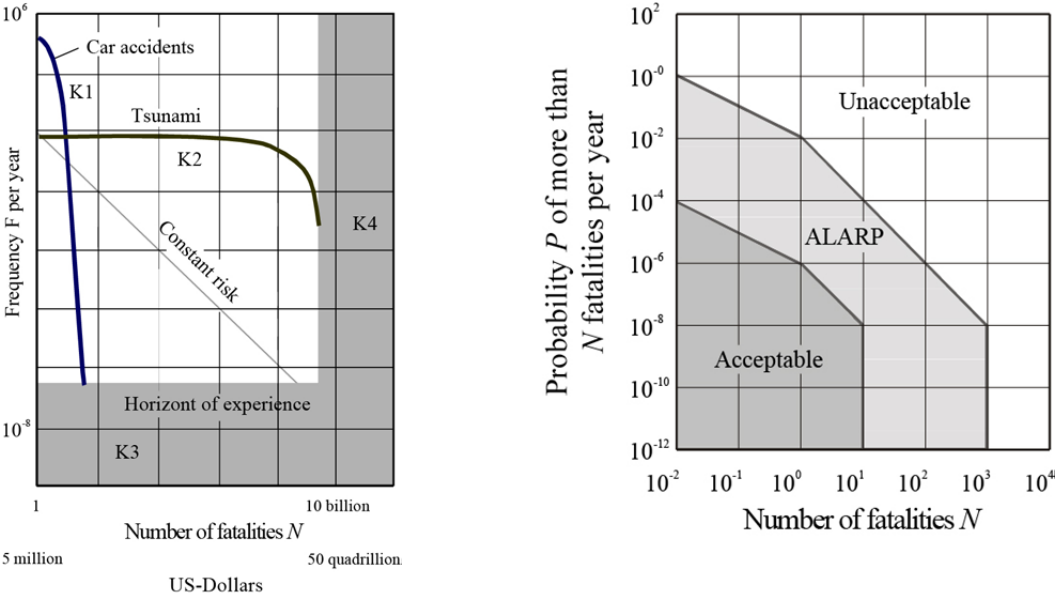

Figure 2: Representation of probability, fatalities and risk [12]

Dams are important parts of our infrastructure with respect to renewable hydroelectric power, drinking water, flood protection, irrigation, and recreation. On the other hand if dams fail they can cause a severe loss of lives, economic disasters, and extensive environmental damages. Dam safety requires an integral concept of structural safety, monitoring of the behavior, safe operation together in combination with maintenance and emergency planning [11]. Additionally, a security assessment of dams with respect to public safety can estimate the threat, the vulnerability of the plant, and finally the probability of an undesired event to occur and can, thus, improve the effectiveness of security protection systems.

We realize by the means of facts that structures designed by engineers are safe. However, we see small dam structures built without thorough technical background to exhibit high potential of risk. The challenge now is, to balance the amount of effort and investment to increase the safety and reduce the hazard and level of risk for the society. For many of the existing smaller structures a different approach to cost and benefit is needed. Whereas for existing and new large structures the way to account for and reduce a possibly existing hazard is straight forward based on a traditional approach.

#### 4.2 STRUCTURAL SAFETY

The far most essential aspect of safety with respect to dams is the general concept with the design regulations and work execution. For the technical design of structures regulations and recommendations are well developed, appropriate design provisions are made (Figure 3, 6). These are based upon experience and good practice and are often referred to as “state of the art”. New developments are benchmarked with the experience gained from existing structures [4].

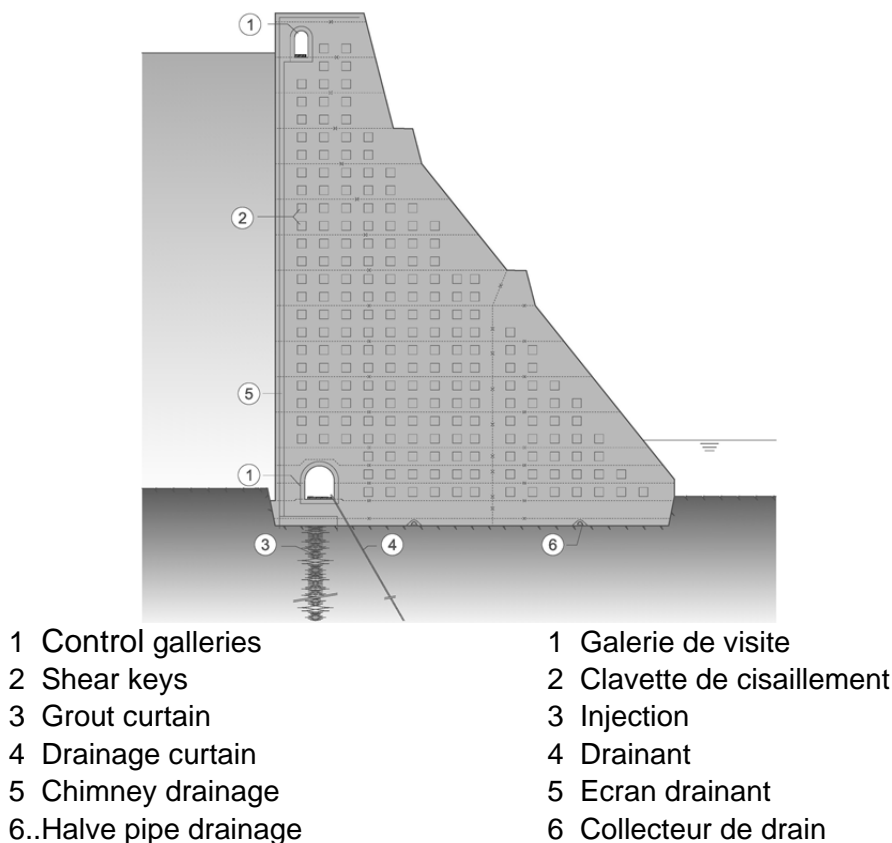

Figure 3: Design provisions – gravity dam



For the design basic assumptions (Figure 4) are dependent on the availability of general information about precipitation, topography, geology – geohydraulic, seismicity [3] etc. and experiences paired with engineering judgment. Finally, the social economic decisions based on the participation of society are decisive for the realization. From the engineering point of view it is essential that the layout with the basic concept is consistent.

The design has to entail how the work can be executed, which material shall be used and how the quality assurance of the executed work is to be guaranteed. It has to be clearly stated that the design and regulations are one part and the other is the execution of the work and the continuous quality monitoring.

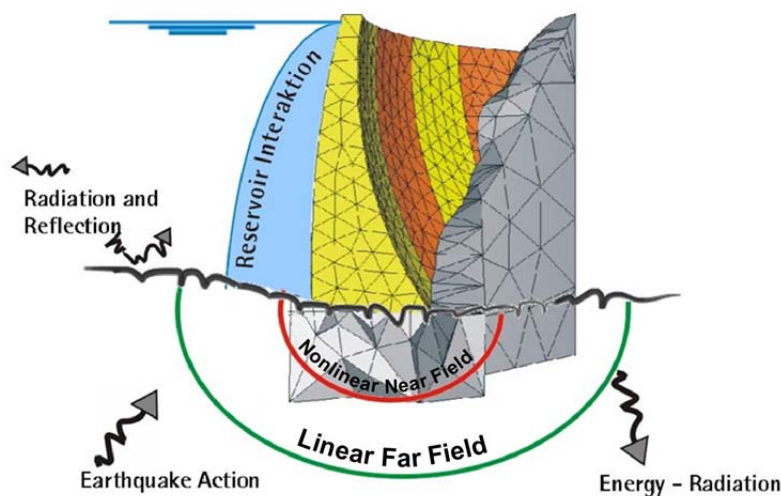

Figure 4: Loading interaction on dam structure

The feedback to the work carried out is important and has to be part of the contracts with a transparent view of responsibilities (Figure 5). The importance for the designers and engineers to discuss their decisions and explain their assumptions taken to an independent body of experts should be worth to be considered as very helpful. It should be appreciated to learn from experience gained of dam structures under operation, of monitoring results and to verify the applicability of models anticipated with the behavior. Numerical procedures are considered as very helpful tools to investigate the influences of the system layout variability as well as components to increase the safety.

It is essential for the engineers to use reliable methods and to be confident about the results. A very good opportunity to see and experience the broad range of e.g. model application and result interpretation is documented in the Bulletin "Guidelines for use numerical models in dam engineering"; the models are based on ICOLD benchmark workshops carried out recently [4]. The procedures are intended to interpret the behavior of existing dams under operation and to assess their safety, to predict the stability of the structure under the simulation of failure mechanisms, with the aim to carry out pre-design and optimization for new dams.

To find appropriate numerical models needs as a prerequisite that one has already gained experience with existing dam structures and their performance; therefore reference to experience is essential [6].

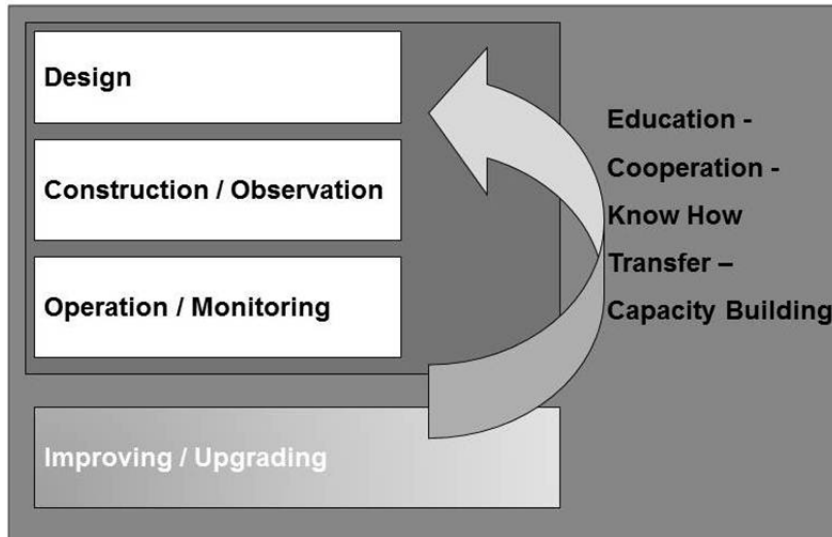
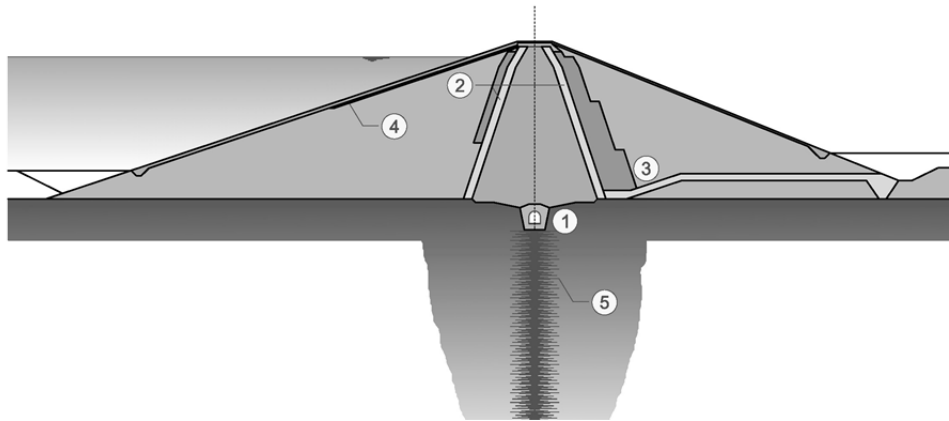

Figure 5: Feedback diagram – design - improving

For dams the general design loading can be determined very accurately and therefore the impounding of the reservoir with the incremental increase of the loading is the opportunity to verify the essential assumptions on the structural behavior. For all large dam structures it is a prerequisite to develop models to account for the bearing and the system response. The assumptions made during the design can be verified by monitoring during the impounding and further on during operation. For dam structures already in operation for a certain time different monitoring approaches are executed. These are based on the dams' category and importance, and are, or at least should be common practice. Very interesting results revealed a PhD thesis [9] about number of measurements, measurement intervals, remote monitoring, and visual inspections on the overall system safety.

Engineering science is naturally based on a positivistic approach and we are aware that under the prerequisites described earlier, we monitor only what we expect to see, what our models permit. Under these conditions the process is self-fulfilling with which we are confident as long as the expected happens. In general we are very confident with the developed models based on the experience – however – there are to some extent always hidden facts which might appear e.g. when we reach limits of applicability in our models due to the assumptions applied. It is very essential for our community to discuss observations very freely and to find better, more appropriate and less complicated models. This process must not be prevented by legal or economic aspects for the sake of our society.

During the next decades we will design and built larger dams under even more complicated topographic and geotechnical conditions and we have to exceed the limits of confidence. Therefore we need careful and thorough consideration of findings.



- |                   |                      |
|-------------------|----------------------|
| 1 Gallery         | 1 Galerie de visite  |
| 2 Filter          | 2 Filtre             |
| 3 Transition zone | 3 Zone de transition |
| 4 Riprap          | 4 Riprap             |
| 5 Grout curtain   | 5 Injection          |

Figure 6: Design provisions – fill dam

#### 4.3 RISK ASSESSMENT

Based on structures designed according the “state of the art” an accepted residual risk still remains for these structures to malfunction. No limits on imagination for opportunities exist as these could be e.g. overloading, operational defects, alteration of structural parts, seepage. No matter how well and sophisticated the dam is designed, constructed, operated and maintained, a certain residual risk will always remain.

To account for the interdependences the development of a hand book about system parts might help. To get an overview on the operation so called “fault tree assessments” are practice and provide an appropriate approach (Figure7). With this method it is possible together with a statistical procedure to calculate the probability of failure. With this rational approach it is possible to account for hazard and compare different scenarios.

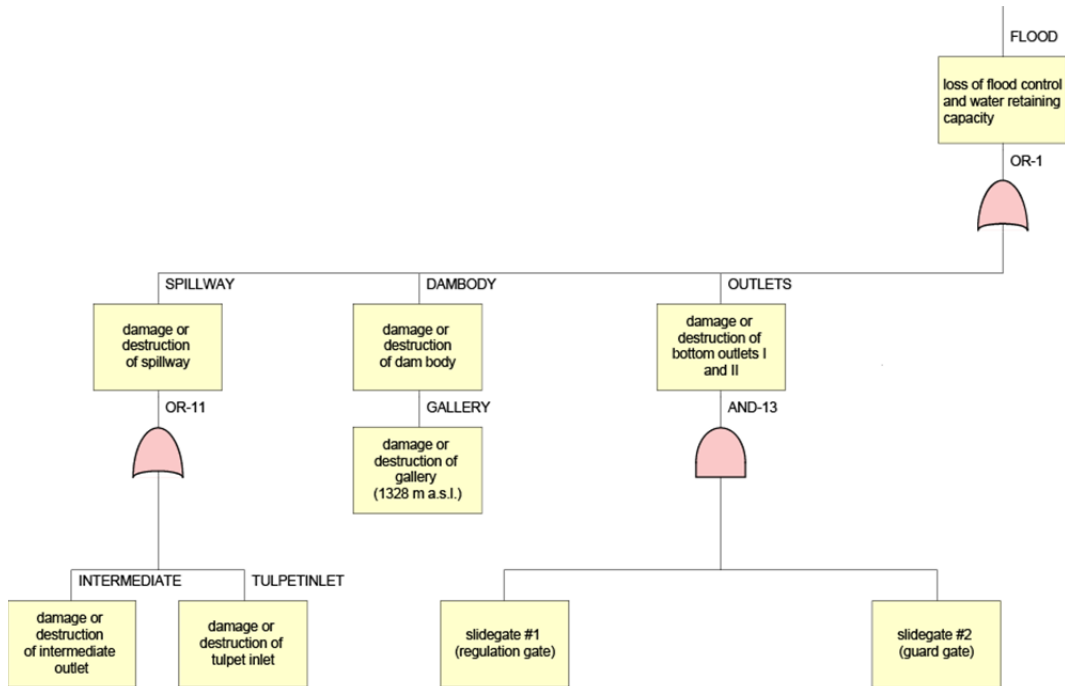

Figure 7: System - fault tree representation

Small hydraulic structures could be constructed without an engineering design. Such a “design”-procedure is very dependent on the legal situation in a country and additionally on the age of the dams. Therefore a high risk is associated especially with these kinds of small dam structures which need to be specially accounted for.

For investments into infrastructure to protect the public from hazard a cost benefit comparison with an integrated risk assessment should be carried out to - theoretically - guarantee the best investment of the money from the public. At the moment such procedures are implemented in e.g. by the European flood directive. During the phase of implementing new safety regulations and procedures to account for precisely the implementation, the estimation of such measures should be part of the process and provide an answer to the question: “How much is safety worth?” and is it worth to be invested in.

To gain an overview about the safety situation of a specific site installation an event tree representation of the interdependencies is common to identify the most likely failure paths with their probability of occurrence.

#### 4.4 PUBLIC SAFETY

Public safety is defined as the safety consequences for the public (excluding dam failures) from the existence and operation of dams and dykes including changes in the water regime [10]. The areas considered comprise upstream reaches, intakes, dams, spillways and areas downstream affected during normal operation of the plants.

There are obvious interrelations between dam safety and public safety but there are also significant differences. One reason for the concerns for public safety is the fact that the number of injuries and fatalities caused by other hazards exceeds in some countries the amount of those caused by dam failures.

With this background European members of ICOLD decided to form a working group on the subject public safety with the aim to learn from one another, to support cooperation and exchange of experience [5]. This exchange among member countries and individuals about safety for the public living in the vicinity of dam and waterways is promoted. Different legal and management concepts are to be compared – public participation is a critical issue.

Preliminary Screening Procedure									
Dam description			Dam missions loss	Consequences Assessment					
Type	Year of construction	Storage Capacity		Public Safety	Economic	Environmental	Total Score	Classification	Full Security Assessment ?
TE - Earthfill Dam	1966	50.7 mio m <sup>3</sup>	x Loss of Flood Control or retaining capacity	10	10	10	30	H	YES
			x Loss of Hydroelectric Generation		8		8	L	NO
			x Loss of Water Supply and Irrigation		n/a	n/a	0	n/a	NO
			x Loss of recreation, tourism		10		10	M	YES
			x Loss of Commercial Navigation		n/a		0	n/a	NO
			Tot. Score	10	28	10	48	M	YES
VA - Gravity Dam	1970/71	126.5 mio m <sup>3</sup>	x Loss of Flood Control or retaining capacity	10	10	10	30	H	YES
			x Loss of Hydroelectric Generation		8		8	L	NO
			x Loss of Water Supply and Irrigation		n/a	n/a	0	n/a	NO
			x Loss of recreation, tourism		8		8	L	NO
			x Loss of Commercial Navigation		n/a		0	n/a	NO
			Tot. Score	10	26	10	46	M	YES
VA/PG - Gravity / Arch Dam	1982	0.22 mio m <sup>3</sup>	x Loss of Flood Control or retaining capacity	8	8	8	24	H	YES
			x Loss of Hydroelectric Generation		6		6	L	NO
			x Loss of Water Supply and Irrigation		n/a	n/a	0	n/a	NO
			x Loss of recreation, tourism		n/a		0	n/a	NO
			x Loss of Commercial Navigation		n/a		0	n/a	NO
			Tot. Score	8	14	8	30	M	YES

Consequence classification			
Single mission loss	2 <= S < 10	10 <= S <= 20	20 < S <= 30
Multiple mission loss	4 <= S < 26	26 <= S <= 53	53 < S <= 80
Category	Low (L)	Medium (M)	High (H)

Figure 8: Safety screening procedure

As indicated the safety of the public around dams and water ways is of increasing concern in many countries. For Europe it can be stated that France and Norway are in the forefront when it comes to creating a more systematic work in that field. This issue needs further attention in Europe and abroad.

Therefore one of the outcomes of the Working Group has resulted in creating a new ICOLD Technical Committee to address this important subject of Public Safety around dams [5]. European countries are well represented in this committee and could take the lead in further development. Additional national committees are recommended to follow the work of this new committee.

Another essential aspect and main issue is to protect dams against unpredictable occurrences such as terrorist attacks and sabotages.

For such aspects a risk-based methodology for the security assessment and management of dams was established under the scope of a research project called DAMSE (A European Methodology for the Security Assessment of Dams) [7]. Selection criteria for the dams investigated were the accessibility of the dams and furthermore the consequences in case of a dam failure.

The consequences for each loss are split into public safety, economic and environmental impact. A classification of these consequences determines selection criteria for low, medium, or high risk. Public safety – under these criteria - depends on how many people are at risk. The economic impact depends on a large number of factors such as the severity of commercial damage, infrastructure, dam reconstruction, affected economy, production, and so on.

Based on that screening (Figure 8) fault trees are developed for the envisaged cases of damage. The fault trees allow the identification of the most critical components of the dam site and show them in detail. The result is a logical illustration of the relationships of all components that can cause the facility to fail.

The full risk assessment delivers information about the security of the dam and possible weak spots and helps creating an amelioration of the security.

#### 4.5 RISK MANAGEMENT

Risk management includes the investigation of hazards and establishes hazard maps. Together with infrastructure and properties the risk assessment is carried out and provides the basis for action plans. However, if hazard is identified it is possible to account for that situation with e.g structural or nonstructural measures [1].

For example hazard evaluation for a current flood situation of infrastructure with risk zoning (Figure 9) in order to establish risk management plans are under preparation throughout Europe based on the flood directive. This will lead to an increase of the individual sensitivity in society and as well as to increase of transparency of investments in safety measures. For an actual situation – for which risk assessment is carried out - it is useful to establish:

- Warning System
- Risk Communication
- Crisis Management.

Effective warning of the population if a dam failure has to be awaited based on monitoring and trained procedural decisions is a major factor in minimizing the loss of life. Emergency action planning and early warning systems increase the effectiveness of results and is beneficial not only for failures but also to mitigate flood events for operational reasons (public safety).

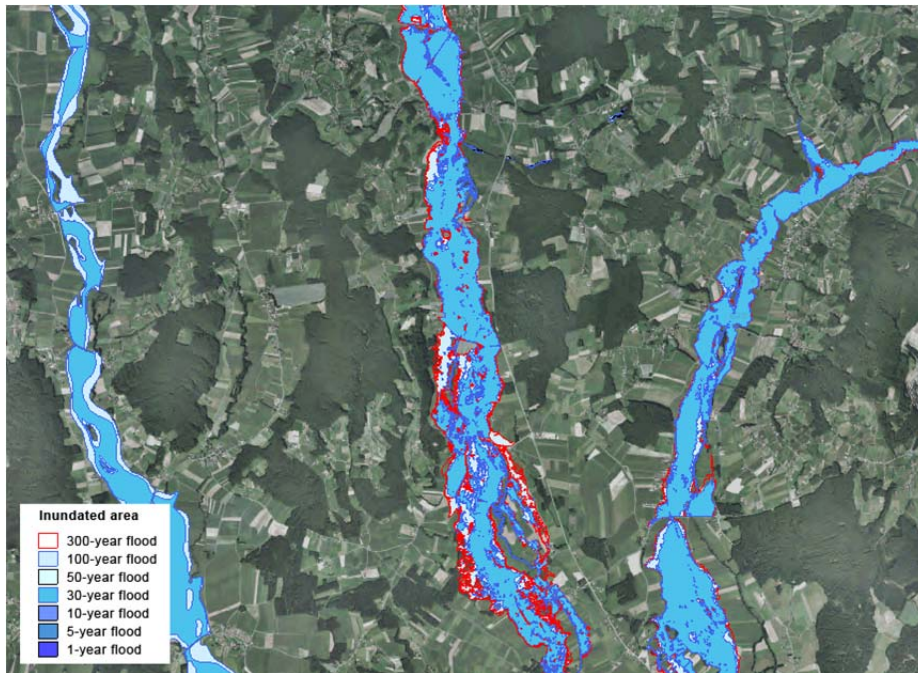

[www.gis.steiermark.at](http://www.gis.steiermark.at)

Figure 9: Flood inundation map – risk zoning – Gis Styria 2012

To be prepared for and manage an actual emergency situation the communication and training plays an essential role. For this kind of interaction the organizational structure in a country has to be accounted for. One approach for investigating and raising the risk awareness could be the development of a questionnaire. This could be implemented in communities (cities, villages) or counties. The method could be applied by a wide range of people such as personnel of municipalities, stakeholders as well as researchers to improve the emergency planning and crisis management, as well as the general risk management as e.g. for floods. The empirical analysis of public opinion poll investigates the attitude of people affected by hazard events, their attitude towards risk perception, their sensitization for risks, towards existing prevention orientation, and the importance of risk communication in the general context of risk management.

General recommendations can be given, and the necessity for adaptations has to be emphasized. Despite the fact that the development of individual states in Europe can be considered high, the process of implementation of common directives makes apparent significant differences. For example the outcome of a

European founded research project SUFRI (Sustainable strategies for urban flood risk management) [8] compared to the aspects during UFRIM (Urban Flood Risk Management: Approaches to enhance resilience of communities) conference should be pointed out.

#### 4.6 EDUCATION AND CAPACITY BUILDING

Education and capacity building plays an important role in the field of dam engineering – as it does in general in society. During the service life of the dam structures more than only one engineering generation is involved. Therefore education, know how transfer and capacity building plays a more and an increasingly important role. Engineers help actively to shape the future. They plan and supervise the entire constructional infrastructure of a society and the variety of job opportunities is correspondingly broad. They range from activities such as planning offices and public administration, research and teaching at universities, universities of applied science and technical colleges to freelance work as civil engineers. On top of these are management tasks in the field of construction, business and ecology - whether in international construction companies or local authorities. The increasing needs of society result in a lack of engineers.

Therefore it is to improve the attractiveness of technical studies in society. From the very beginning the education of children under the premise of transparent and comparable curricula can initiate certain mitigation in the long term range. The current need can only be mastered with “training” provided for employees on the job, special courses and programs as well as an improved effort within the established education system.

Education in consideration of the historic development, the social, regional and ethic differences was identified to be a future key issue to an open minded society. As a consequence of the “Bologna Process” the educational system in the European member countries is being reshaped currently. It is anticipated that the educational process at Universities will be to a higher extent comparable. This will support the flexibility of students to select Universities of their choice and spend semesters abroad. On the other hand, the education has to assure that the graduate fulfils certain criteria for the engagement and that the graduation enables to conduct responsible work. Especially for graduates in the field of engineering there exists a high demand. The main aim should be to attract a higher number of students for engineering sciences and to keep the courses at a level of high quality.

During the last decade significant changes in personnel resources for design, construction, and operation of dams have occurred. This occurred not only for economic reasons (liberalised electricity market, very often resulting in the reduction of staff), but also due to rapid developments in the field of automation and remote control. In order to master the challenges of the future and to meet the demands for renewable energy, design and construction of new dams will become an increasingly important issue, whereas existing dams must be operated, maintained, and upgraded by competent personnel to the same extent as it has been so far.



For example the 8<sup>th</sup> ICOLD European Club Symposium, which was devoted to the topic “Dam Safety under the Sustainability in a Changing Environment”, considered several key aspects and especially e.g. education and knowledge transfer attracted high interest [7].

The exchange of dam related knowledge and experience within the international community by actively supporting the work of the International Commission on Large Dams (ICOLD) resides in National Committees too. For example ATCOLD (Austrian National Committee on Large dams) arranges periodically education and training courses for people working in the dam field, thereby supporting its members – the great dam owning companies of Austria as well as consultants and contractors – and other interested entities by providing a basis and supplement to the “training on the job” activities. There are courses dedicated not only to dam attendants and operators of large dams, but also courses for owners of small dams and reservoirs in order to raise their awareness of dam safety requirements and to enhance the necessary knowledge in this field.

On the academic level, courses for Dam Safety Engineers are held at regular intervals. During 4-5 days, dam safety issues are covered in general as well as in detail (dam surveillance techniques and safety management), including brief on site demonstrations.

Special seminars on “Dam Surveillance Practice” are offered for the international engineering community [13]. These kind of seminars covered relevant questions regarding the surveillance and safety assessment of dams. Experts reported on the theory and practice of dam engineering, instrumentation, execution of measurements, visual inspection, data processing and safety evaluation for concrete and embankment dams. The theoretical part was supplemented by practical work at dam sites, including aspects of site inspection. The participants were encouraged to present their own findings and conclusions from site inspection and safety assessment. Sufficient time was available for discussing dam surveillance matters in detail. A high number of lecturers and trainers allowed for very intensive and effective work. The participants from all over the world gave a very positive feedback to the organizers and the seminar was successfully devoted to provide a common understanding of dam surveillance and knowledge transfer to young engineers being involved in this field.

The changing abilities required of engineers need a modified approach of the knowledge transfer in companies and society. An individual adaptation to this situation can be assumed, a more systematic approach is required.

## 5 CONTRIBUTIONS

### 5.1 ACCIDENTS AND INCIDENTS IN DAMS AND RESERVOIRS – RECENT CASE STUDIES

Engineering sciences applied have the huge advantage of obtaining empirical evidence and the proof of verification. However, evidence in this sense is based on sound theoretical knowledge elaborated by uncertain elements e.g. loading, foundation, specific material etc. With the help of these components and the engineering imagination models are built to test the situation, to simulate scenarios and therefore to prevent failures. To prevent a structure from failing without any early warning signals, monitoring instruments are installed – however – to monitor a somehow “anticipated event”. The question which arises is could there happen - under certain circumstances - an unexpected, not envisaged event?

Therefore a solid database of case studies is essential for our community to increase the knowledge and understanding. Despite the fact that the contributions sometimes do not present the entire picture of the engineering scope of duties they nevertheless provide valuable information.

A general overview based on **statistical evidence** is given in R31 – Lessons learned from dam safety incidents in South Africa – for a time period of more than hundred years. In this contribution a definition about incidences and failures are referred too – as an incident implies the potential for uncontrolled release of a significant portion of water and includes incorrect operation of operating devices – whereas a failure is an uncontrolled release of water due to failure of dam structure.

Significant portion of incidents are reported during construction and first filling of reservoirs dating back to the fifties. It is shown clearly that the promulgation of the dam safety legislation in the country had a significant positive influence on dam safety, since then no failure of a large dam structure occurred.

A database on internal erosion of **incidents** in R23 including dams, dikes and levees is structured to get the best possible overview of the situations. No failure of hydropower canals is reported.

For levees in about 50% overtopping is clearly identified as cause of failure; whereas of about 10% this is clearly internal erosion. In other cases it was not possible to clearly identify the cause of failure. Further research about correlation is needed. Critical information on the characteristics of erosion resistance of the fill and foundation is often missing.

For embankment dams 30 cases of internal erosion are reported in France, of which six are failures. No large dam was affected by internal erosion, though the hydraulic gradient is higher, which can be seen as an indication for appropriate engineering.

Improved **hydrological analyses** would help for adequate spillway design, which is a major cause of problems during operation. Dam safety inspections and diligent monitoring are important tools for early detection and consequently also to prevent probable failures. Implementation of proper operation and maintenance procedures as well as emergency plans is effective to reduce serious incidents and number of lost lives.

The prevention of loss of electricity and the necessity to open gates manually is explained to have reduced the danger of dam overtopping during a flood event in R1.

A hybrid rainfall prediction based on radar data and a meso-scale atmospheric model is explained for proper management and operation of dams for hydro power production in R44. A prediction achieved is shown to be possible within six hours ahead. The rainfall prediction system is combined with a distributed run off model as well as with an inflow analysis.

**Seismic aspects of dams** attract a very high attention from the public and the engineering community and are associated with high risk in reference to the structures. During recent events the hazard was shown to be evident. Therefore, the safety evaluation earthquake needs to be confirmed with no failure and uncontrolled water release. The safety assessment of existing dams plays an important role and provides valuable experience for new designs.

The state of the art for seismic design developed significantly after the sixties, which required and still requires adaptations and reassessment of existing dams in accordance with new guidelines and improved knowledge.

In R11 the effort on seismic safety assessment is reported for Switzerland. It is shown by the application of recently new implemented design criteria that only few dams – which were designed in accordance to older regulations – needed remedial measures. It is remarkable to read that dams which needed to be upgraded had already a static bearing behavior which was questionable.

Many buildings near Lorca (Spain - R28) were affected by an earthquake of relatively small magnitude. Due to its shallow depth maximum accelerations between 0,27g to 0,37g are recorded at the dam site. Post-Earthquake inspections revealed maintenance problems of hydraulic steel structures but showed the overall good performance of the large dam structures. However, rock fall was an issue to mention and to be kept in mind for risk assessment.

**Hydraulic structures are designed** and constructed in accordance with regulations and recommendations. However, a first and essential way for the adequate design is the underlying model which has to be verified with the help of available information.

For the bottom outlet conduit which is regularly under pressure from a reservoir head of about 48m a failure is reported by R3. A totally uncontrolled release of water could be prevented by means of an emergency gate. Under these circumstances of failure a second operating gate would not have helped to overcome the situation.

**Examples** of risk and safety assessment are given and described herein. As example for hazard studies to assess in more detail the intrinsic safety level of dams and their appurtenant structures the reliability method is examined in contribution R21. For a gravity dam designed in compliance with good engineering practice it is shown that the reliability level is very high.

In contribution R 5 the risk assessment for two dam structures is given. First the investigation is specified to compare different types of structures – arch dam and fill dam respectively.

The influence of the slope stability on the overall safe system behavior is studied in R6 and it has been determined and described that monitoring, reshaping and the provision of drainage provide adequate stabilization measures.

To improve the **serviceability** of a concrete faced dam structure remedial works by means of an applied PVC membrane is explained in R8. The retention of water and prevention of seepage in case of a CFRD structure is seen as serviceability concern and not that much as a safety concern.

In R26 for a 170m high gravity dam cracking at its upstream face due to high temperature gradient after impounding is explained. Under high water pressure it was the challenge to seal the cracks with appropriate injection pressure and with an appropriate resin against flowing water to reduced water losses and guarantee system integrity.

Warning systems are essential in case of emergency and need a careful layout, well established initiating system and training. The installation of a warning system by a utility is described in R7. Based on legal frame work the chain of information and parameters are summarized for reservoir related risk management.

From experience gained during dam safety evaluations in R18 recommendations for improvements are given e.g. an adequate drainage system for fill dams is and ought to be important, the maintenance of earth dams is essential to repair wave erosion, animal activities and trees to avoid stability problems. Maintenance of hydraulic steel parts is mandatory. If pre-stressed cables are used for the stabilization of gravity dams these should be able to be tensioned again and tested from time to time.

Investigation of **potential failure mode (PFM)** assessment is carried out as part of safety action classification for a multiple purpose dam in R22. Detailed investigations of the structure and the geology of the foundation are carried out to detect failure modes. PFM judged to be credible and highlighted for further risk evaluation are related to spillway, to overtopping, to earthquake seismic response, potential of internal erosion, and piping.

System response event trees provide a good overview of the entire “system behavior”. Based on these potential failure mode analyses are carried out and completed with a detailed risk analysis.

## 5.2 RISKS ASSOCIATED WITH HUMAN AND ORGANIZATIONAL FACTORS

The monitoring of the structural behavior and the provision of reliable data is a key issue for safety assessment. As the available data are based on measurement installations which again rely on engineering judgment and the previous experience with comparable systems, the preparation and interpretation of data is vital. However, the essential contribution is the data interpretation and the consequential action to be undertaken based upon rational decision. At this point the education and capacity building should be emphasized to play an important role in guaranteeing continuous engineering assessment of dams.

In R13 the question is posed, whether an automated data acquisition system with a data processing and management system are contributing to dam safety. In general the degree of automation is not regulated, this issue is decided upon from case to case. Data processing and the appropriate presentation of the results as well as the range of data can provide a powerful tool to get a quick system overview. It is concluded and demonstrated by means of examples that the degree of automation alone does not contribute to the assessment of a dam's safety.

The competent and reliable communication about the actual situation during an emergency is vital. The population needs reliable information and should be trained and know about what kind of appropriate corresponding actions ought to be undertaken. During an emergency event, the supply of electricity and the availability of communication lines are vital. The way to overcome such shortcomings is described in several case studies (R1).

Risk analyses tools are useful for decision making – and provide the possibility to compare structures with one another and help, thus, to decide for a system of dams about the most efficient measures. In contribution R33 in addition event trees are used to describe the interdependency of system components by means of nodes on their entire performance. As a result risk is evaluated associated by referring to the event tree. With this method it is possible to investigate the potential of risk reduction associated with human and organizational factors as e.g. an emergency action plan.

The effect of the mechanical equipment on the safety of structures is highlighted in accounting for redundancy and the condition of installation. Especially in regard of the maintenance methods in R34 a classification by social significance and reliability analysis is used where the social impact can be classified high, medium or small. Failure mode and effects (FMEA) and fault tree analysis (FTA) are carried out dependent on the kind of device. By means of categorization a new maintenance method is established, to maintain a “high safety level by reducing costs”.

For high dams in Austria it is required to totally empty the reservoir for inspection of all relevant parts. The total emptying of a reservoir after 20 years of operation explained in R17 needed special additional permissions – e.g. ecological permission in combination with an accompanying monitoring program; exception from reservoir regulations, and the involvement of the water authority of the neighbor country due to the proximity of the drawdown. The inspection revealed that the bottom outlet structure and the headrace tunnel were in a good operable condition. Only minor repair works were necessary. The emptied reservoir showed some depression cracks in the flanks above the headrace, which needed intervening action. Ecological concerns were attributed utmost attention to.

Early warning is identified essential in case of emergency to reduce loss of live in China (R41). Hazards are to be reduced by detection of potential danger, monitoring and inspection of operation conditions as well as are to prevent difficultly predictable events such as sudden dam breaks. Lessons learned are summarized for reservoir dam emergencies, which can be influenced by monitoring, warning alert, information passed on to public, and to activate an alarm. The discussion includes internal early warning, information published and alarm.

### 5.3 REGULATORY CONCEPTS, GUIDELINES AND GOOD PRACTICE

In general, the safety concept relies on solid and sound design as well as construction principles in combination with an adequate surveillance and maintenance of the entire system. For the residual, remaining risk an emergency plan needs to be defined with an alarming chain. During the lifetime of a structure major and minor adaptations are required, based on safety assessment. This requires a solid support from stake holders. The status of current regulations or the development of new regulatory concepts are discussed by authors from several countries – Sweden (R2), Poland (R4), Russia (R5), Swiss (R9), France (R12, R14) and Spain (R24).

The reassessment of the existing dam safety system in Sweden is explained in R2. Of in total approx.10.000 dams, 500 are categorized as high hazard in three levels according to the consequences in case failure occurs. The highest consequences could lead to a loss of lives and to intermediate considerable damage of important installations. No specific law on dam safety currently exists; the dam owner is responsible by means of self-regulation. An independent national dam safety authority was assigned to have a peer review for existing dam structures. Reviewing was carried out and made evident that the current situation is inappropriate. The current situation of dam safety does not fulfill the social requirements and calls for more explicit regulations on dam safety. This action is motivated by the situation of high hazard dams. It is recommended applying a dam safety strategy, especially, for the highest category.

In general no specific regulations concerning the technical conditions of hydraulic structures existed in Poland. It is the obligation of the owner to apply necessary precautions. No independent body (dam monitoring center) was enforced to control and inspect dams. Binding legal regulations are in force since joining the European Union in 2004 and have been developed from 1989 onwards. These safety conditions are explained in contribution R4. Since 2011 a national dam safety survey has been conducted on the basis of regulations in the water management act. All dam structures are incorporated. Further adjustments in test, measurements and evaluation methods are considered necessary. In the contribution the necessity of systematic trainings for the staff in charge of dam safety (dam safety engineer) as well as the dam attendee (monitoring technical conditions) is emphasized. Further works for adjustment of dam safety control to fulfill ICOLD recommendations are cited.

The adaptation of the existing legislation and the redistribution of responsibilities more precisely under the consideration of the interdependencies are explained in R9. The ordinance from 1998 is actually in force and is in the process of adaptation on the basis of the New Dam Safety Act. Different new key components of the new ordinance are described, highlighting new responsibilities for the dam height and reservoir volume, as well as new provisions for the dam operator's liability. However, as this is a democratic process which needs a public consultation procedure with controversial discussions in a country conducted in a highly elaborated federal culture, the process is very time consuming.

Since 2007 a new classification was introduced in France (R14) to take risk into account. Especially for dams with lower height, the classification provides requirements which were little or even not existent earlier. For "class A" dams safety review every ten years based on complete technical check-up and updating of risk assessment is required.

Recent changes in seismic zoning in the year 2010 and a major update of dam safety regulation for hydraulic structures are described in (R12). In general the semi probabilistic framework of the Eurocode serves as a basis for new earthquake regulations. Specific approaches are required for large dams and in areas of high seismicity and of complex geology. Safety checks need to be carried out for Safety Evaluation Earthquake and Operating Basis Earthquake which serve as a proof for the serviceability limit state. Post-earthquake review is in accordance to recommendation of ICOLD Bulletin 62 – revision 2008. A recommendation is given, that "class A" dams located in zone 5 should be equipped with seismic monitoring instruments.

In Spain the safety of dams, ponds and reservoirs is regulated in a decree and the classification of dams and ponds is undertaken within A/B/C – categories dependent on the height and reservoir volume as well as the risk associated with the structure. In future - based on the requirement of new standards - investments from private owner and communities will be necessary. The costs to

collect data for a complete safety assessment are estimated by contribution (R24) to adapt 60.000 ponds to fulfill the new requirements.

Draft guidelines for seismic performance evaluation of dams during earthquakes are set up in Japan. For seismic performance of large gates performance verification are constantly improved by Japan dam engineering center (JDEC) and explained in R40. A detailed numerical procedure to verify the dynamic performance of gates is shown with the help of finite elements, introducing the structure water interaction. The equivalent energy assumption is used to calculate plastic strain. Little information about the real system behavior is available, because monitored earthquake events are rare.

#### 5.4 SPECIFIC RISKS FOR SMALL DAMS

Small dams constructed for flood protection represent often a high level of risk. Many dams are wide spread and expenses' reduction for design and construction is a great temptation and sometimes even required. High risk is associated with small dams which are not maintained and observed conscientiously. Especially for flood protection levees were constructed, however very often with an uncertain safety standard.

Due to the inherent risk associated with these small dam structures, the need to be designed, constructed and operated with as much rigor as dams with a permanent water level is highlighted in contribution (R15).

In Indonesia (R16) many small dams – called situ – were built for irrigation and to protect against flood in the early twenties to forties of last century. For these structures only little information is available and especially the risk associated with these structures is not known. After a disastrous event of dam breach in 2009, which was totally unexpected and the population was entirely unaware of its danger, an investigation about the risk associated with these dams was undertaken. Dams which are categorized with relative risk make evident the immediate need to act. Extraordinary events might cause loss of lives and high damages. Recommendations for an action plan to reduce the risk are given – e.g. to increase spillway capacity, reduce the water level in the reservoir and increase the freeboard, take measures for land usage and to carry out proper maintenance.

The US Army Corps of Engineers – described in (R27) – started to engage themselves in flood damage reduction. Nationwide no inventory of levees exists, especially the creation of flood maps for emergency cases would require reliable data. The layout of the database is rationalized with its major content. With a correlation to hazard maps losses can be estimated. As the collected data are sensitive the access to the data base is restricted. This national levee database is to be used for emergency management, risk screening, engineering and construction. It is essential to mention that these data need the appropriate



context, structure and permission to be used, otherwise the danger for misinterpretation exists.

In Sri Lanka during floods in 2010 and 2011 three medium and nearly 500 small dams breached. The lessons learned are summarized in the contribution (R35). The protected land lies below mean sea level, after the breach of some dams the emergency preparedness plan could not be applied. Several heavy rainfalls led to fill up the reservoir and for following events no retention was possible. The spillways need to be designed for maximum run off. As it is typical for this region many small dams were managed for drought periods and were not prepared for heavy floods. Dam safety issues were the inadequacy of spillways, structural defects due to loss of freeboard, damages caused by traffic along the crest, piping in the untreated foundation, blockage of spillways, lack of maintenance, shortcomings of operational procedures, lack of coordination among different organizations. The flood event highlights the importance of total river basin management and the necessity for a concerted action plan.

In China, on the 12<sup>th</sup> of May 2008 the Wenchuan Earthquake hit the Sichuan province for which a data base of dam damage has been established and which is described in (R37). Crack, leakage, structural deformations and landslide are the major hazards. Dams within an epicentral distance of 40km were totally damaged, above a distance of 200km only 10% damage occurred. The dams with high hazard were with 95% rock- or earthfill dams. The dam hazard degree is mainly dependent on epicentral distance. 30% of existing dams were damaged, 90% of which were small dams.

In modern China in total 3500 dams breached, due to various reasons, nearly all of them were small embankment dams. Flood occurrence on account of dam breach is unleashed by the breach process. With the statistical data available in R38 a method to anticipate the flow duration curve is given. The peak outflow curve in the contribution is approximated by means of curve fitting from historical data and is not related to a physical model and does therefore also not simulate the real situation.

#### 5.5 RISKS SPECIFIC TO TAILING DAMS, PUMP-STORAGE SCHEMES, FLOOD CONTROL STRUCTURES AND OTHER SPECIAL PURPOSE DAMS

In contributions from South Africa (R18, R19) the determination of design flood and combined with a careful spillway design in respect to pumped storage schemes is discussed. It is recommended for upper reservoirs of pumping schemes to provide a spillway against over-pumping to overcome, thus, possible human failure. Such emergency spillways could however entail retention of a volume available as free board.

Dams are part of a comprehensive risk management framework by incorporating sustainability, resilience and public participation. The contribution

R29 addresses **flood risk identification**, analysis, assessment and mitigation and the role of dams as critical infrastructure. Dams comply with the demands for higher safety levels, security and reliability of critical infrastructure.

Specific aspects arise when the insurance for dams is considered as part of the critical infrastructure. The introduction of an index based on statistical methods, as described in R30, is argued as basis for risk insurance and beneficial for receiving financial support for dam safety.

For a pumped storage scheme the hydraulic design of the bottom outlet emergency gate with the air entrainment is assessed by means of empiric formula in combination with Computational Fluid Dynamic analyses in R20.

The data base established and presented in R23, as a result of a research project on internal erosion in dams and dikes, provides the opportunity for feedback on design and maintenance. Most internal erosions occurred in the foundation and malfunctions were observed in coarse soils. Values of critical Darcy velocity, critical shear stresses and erosion coefficients at failure are provided and should enter design recommendations and regulations.

The entire system layout with the appropriate dam structure, the design principle together with the material used plays an important role in the overall performance. Especially the geological situation at the dam site needs careful investigations and requires a specific dam layout. Under such circumstances in R25 the use of high plasticity clay for a dam layout is laid down. A general section of the dams' geological situation is depicted and the application of filters is additionally explained.

In contribution R32 leakages in joints of a buttress dam inhibited the serviceability of the reservoir and therefore a specific solution needed to be found. The nature of that problem requires a clear understanding of the underlying general physical background and possible interrelations of phenomena to find a satisfying solution.

The contribution R36 accounts for the deformation behavior of a fill dam during and after an earthquake while being under construction. The analysis is based on the Duncan-Chang nonlinear elasticity model with a cumulative damage theory. This investigation provides a better insight into the system behavior compared to a conventional sliding deformation analysis.

Detailed seepage analyses with the formation of free surface within the solid in a project area for a pumped storage scheme are carried out and elaborated in R39. With the demonstrated improved method it is possible to solve the theory of seepage flow under complex geological conditions.

For many dams after the Tohoku earthquake in Japan – as reported in R42 - motions at or above a certain level were observed, special inspections were immediately carried out. The inspections were in accordance to a specific plan on

363 dams with a peak acceleration of 1g at the dam foundation or even higher. The distance of the dam to the source of earthquake was relatively large, though the duration of the quake was long lasting. Only minor damages were reported. Since many earthquakes occur in Japan, valuable monitoring data as e.g. response spectra are available. Some examples are given.

No dams under legislation (large dams) were seriously damaged. Except one old dam, utilized primarily for irrigation, and was not included in the regulation, breached.

#### *5.5.1 Education and capacity building*

Many experienced engineers are retiring and a need of knowledge transfer requires a very high quality level for capacity building of younger engineers. For Japan, as an example, in R43 this issue is highlighted as explored thoroughly. Dam operations for HPPs have to comply with safety regulations and optimal service for efficiency by keeping the water level high. However, before the occurrence of a flood the water level has prior to the increased inflow to be lowered – which is based on experienced operation and combined with simulation on account of forecasts. To simulate such situations in training a portable simulator has been developed to transfer the knowledge from older to younger generations, as this is an actual challenge for dam operators. The training is provided on site, since one training center is not enough. During training the trainee receives feedback from the instructor. The entire system including data transfer and exchange is described in the contribution by providing a flood hydrograph, setting initial training conditions and recording the training results.

## 6 CONCLUSIONS

Safety is a major general issue related to our society and therefore very dependent on social standards, living conditions as well as personal perceptions. Contrary to soft facts statistics provide the basis for a rational approach and provide, thus, the manifestation of the history of political evidence. In which direction the society should evolve and how advanced the safety standard should become is finally a matter of the entire society itself. Therefore, this safety is not only engineering concern but is also dependent on economic factors for remaining affordable and it relates to a high extent to jurisprudential aspects as well.

Safety should be understood as a mean time period developing process which can and has to be assisted by available powerful methods based on science. The information and involvement of the public to lead to better informed politicians, stakeholders and decision makers should help to achieve sound and responsible policy choices, priorities and decisions. The very same process can also be applied to theory, application, observation, maintenance, performance assessment, mitigation measures, and finally emergency preparedness in general.

The way of how to provide the safety of dams and to carry out the required measures is widely discussed within the contributions herein under the topics: experience based on case studies, risk assessment based on public awareness of dams and dam safety, regulatory concepts and guidelines, sustainability of know-how and its transfer, and special maintenance and rehabilitation issues.

Further, it has to be kept in mind that the entire dam safety process needs to be economically shaped and to remain affordable. However, economy has to be altered in a fundamental way to better serve the development of our civilization and not only economy itself. The discussion about, on whether the "safety" process should develop in the direction of a change for a higher unification among different countries or whether to keep retaining the divergent national approaches will help us to understand each other better and will, thus, also provide in itself a general future benefit due to the process of discussion.

## ACKNOWLEDGEMENTS

The response from the authors to the question is appreciated. The contributions and comments made to the General Report by Dr. Oberhuber and Mr. Czerny is gratefully acknowledged. The reviewing of the English text version by Ms. Vitas, the contributions to drawings by Ms. Zechner, Ms. Jöbstl and Mr. Goldgruber is appreciated.

## REFERENCES

- [1] ICOLD (2001) – Nonstructural Risk Reduction Measures – Committee on Cost of Dams - Bulletin E02.
- [2] ICOLD (2005) – Risk Assessment in Dam Safety Management – Committee on Dam Safety - Bulletin 130.
- [3] ICOLD (2010): Selecting Seismic Parameters for Large Dams, Guidelines, Bulletin 72 (Revised 2010); Committee on Seismic Aspects of Dam Design.
- [4] ICOLD (2011) – Guidelines for Use of Numerical Models in Dam Engineering – Committee on Computational Aspects of Analysis and Design of Dams – Final Draft Bulletin.
- [5] Draft Report on “Public Safety at Dams” – by ad hoc working group of ICOLD European Club, released 2010.
- [6] Bauer E., Semprich S., Zenz G.(Editors) – Proceedings of the 2<sup>nd</sup> International Conference on „Long Term Behaviour of Dams“, October 2009, Graz, Austria.
- [7] Austrian National Committee on Dams, - Proceedings of the 8<sup>th</sup> ICOLD – European Club Symposium, Austria 2010,; ISBN 978-3-85125-118-0.
- [8] Zenz G., Hornich R. (Editors) – Proceedings of the International Symposium on “Urban Flood Risk Management”, September 2011, Graz, Austria.
- [9] Franke J., - Einfluss der Überwachung auf die Versagenswahrscheinlichkeit von Staustufen, PhD-Thesis – Dr.-Ing. (in German), Institut für Wasserbau der Universität Stuttgart, (2011).
- [10] Bowles D.S. – Tolerable Risk for Dams: How Safe is Safe Enough? – Proceedings of US Society on Dams Annual Conference, March, Philadelphia, Pennsylvania, 2007.
- [11] Hartford D. et.al. – ICOLD Bulletin on Dam Safety Management – in Proceeding of 8<sup>th</sup> ICOLD European Club Symposium, Austrian National Committee on Dams, Austria 2010.
- [12] Proske D., - Catalogue of Risks – Natural, Technical, Social and Health Risks, Springer- Berlin-Heidelberg 2008.
- [13] Zenz, G., Oberhuber P, - Dam Surveillance Seminar – Kaprun. Hydro Power & Dams (2006).