

# A Measurement System and the *TUG-EEC-Channels* Database for the Aeronautical Voice Radio

Konrad Hofbauer  
Graz University of Technology  
Institute of Signal Processing  
and Speech Communication  
and Eurocontrol Experimental Centre  
Email: konrad.hofbauer@tugraz.at

Horst Hering  
Eurocontrol Experimental Centre  
INO – Innovative Research Area  
F-91222 Brétigny-sur-Orge, France  
Email: horst.hering@eurocontrol.int

Gernot Kubin  
Graz University of Technology  
Institute of Signal Processing  
and Speech Communication  
A-8010 Graz, Austria  
Email: g.kubin@ieee.org

**Abstract**—A system for measuring time-variant impulse responses and a database of such measurements for the aeronautical voice channel are presented. Maximum length sequences (MLS) are transmitted over the voice channel with a standard aeronautical radio and the received signals are recorded. For the purpose of synchronisation, both the transmitted and received signals are recorded in parallel with a GPS-based timing signal. The flight path of the aircraft is accurately tracked.

A collection of recordings of MLS transmissions is generated during flights with a general aviation aircraft. The measurements cover a wide range of typical flight situations as well as static back-to-back calibrations. The resulting database is made available under a public licence free of charge. The estimated time-variant impulse responses provide a characterisation of the aeronautical voice channel. This characterisation is needed for improvements and add-ons to voice communication systems as in air traffic control, where the analogue radio will remain in use for many years to come.

## I. INTRODUCTION

Since its beginnings, air traffic control (ATC) has relied on the voice radio for communication between aircraft pilots and air traffic control operators. The amplitude-modulation (AM) radio, which is in operation worldwide, has basically remained unchanged for decades. Given the aeronautical life cycle constraints, it is expected that the analogue radio will remain in use for ATC voice communication in Europe well beyond 2020 [1]. The AM radio is based on the double-sideband amplitude modulation (DSB-AM) of a sinusoidal carrier. For the continental air-ground communication, the carrier frequency is within a range from 118 MHz to 137 MHz, the ‘very high frequency’ (VHF) band, with a channel spacing of 8.33 kHz or 25 kHz.

Eurocontrol Experimental Centre (France) and Graz University of Technology (Austria) are currently working on embedding supplementary digital data, such as the call-sign of the aircraft, into the voice signal of the analogue air/ground communication [2], [3]. The VHF radio transmission channel has a strong impact on the performance of such a speech watermarking system in terms of data rate and robustness. The degradation of a transmitted signal is studied for the purpose of system design and evaluation.

Sophisticated models of the transmission channel exist, based on which the behaviour of the channel can be derived

and simulated [4], [5], [6]. The dominating effects are path loss, additive noise, multipath propagation through reflection, scattering, diffraction and absorption, as well as Doppler shifts due to the fast movement of the aircraft. The conditions vary significantly with the position and the velocity of the aircraft during flight. The communication channel is inherently time-variant.

Most of the existing channel models contain a large number of parameters, which makes it difficult to obtain realistic simulation scenarios. Unfortunately, very few measurements that could support and quantify the theoretical models are available to the public [7].

The aim of our measurements was therefore to gather time-variant impulse responses of the aeronautic VHF radio channel between the aircraft and the ground-based transceiver station under various conditions.

The outline of the paper is as follows: Sec. II shows the design and implementation of a measurement system for the aeronautical voice channel. Sec. III gives an overview of the conducted measurement flights. The results form the freely available *TUG-EEC-Channels* database, which is presented in Sec. IV. Section V concludes the paper with an outlook on further work.

## II. MEASUREMENT SYSTEM FOR THE AERONAUTICAL VOICE RADIO CHANNEL

Conventional wideband channel sounding is virtually unfeasible in the aeronautical VHF band. It requires a large number of frequency channels, which are reserved for operational use and are therefore not available. Thus a narrowband method is presented, which moreover allows a simpler and less expensive setup.

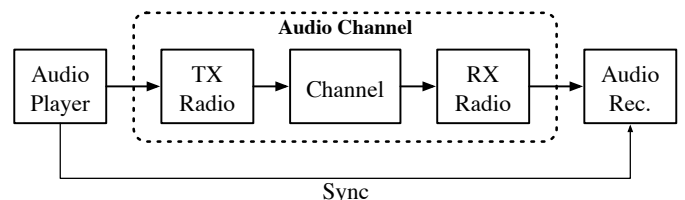

Fig. 1. A basic audio channel measurement system.

Figure 1 shows the basic concept of the proposed system: A known audio signal is transmitted over the voice radio channel and the received signal is recorded. The time-variant impulse response of the channel can then be estimated from the known input/output pairs.

Measuring the *audio* channel from baseband to baseband has certain advantages and disadvantages. On one hand, besides its simplicity, the measurement already takes place in the same domain as where our target application, a speech watermarking system, would be implemented. On the other hand, it does not reveal a number of parameters that could be obtained with wideband channel sounding, such as a distinct power delay and Doppler spectra. Although these parameters cannot be directly measured with the proposed system, they do have an effect onto the audio channel. To determine the severeness of these effects is the focus of interest.

#### A. Synchronisation between Aircraft and Ground

As already indicated in Fig. 1, it is necessary to synchronise the measurement equipment on the transmitter and the receiver side. This linking is necessary as the internal clock frequency of two devices is never exactly the same and the devices consequently drift apart. Moreover, the clock-frequency is time-variant, due in part to its temperature-dependency. But, in a setup where one unit is on the ground and the other one is in an aircraft, the different clocks cannot be linked and a direct synchronisation is not possible. This problem is common to all channel sounding systems.

In high-grade wideband channel sounders a lot of effort is put into achieving synchronisation. In former days, accurately matched and temperature-compensated oscillators were aligned before measurement. Once they were separated, the systems still stayed in sync for a certain amount of time before they started drifting apart again. In modern channel sounders atomic clocks provide so stable a frequency reference that the systems stay in sync for a very long time once aligned. Such systems are readily available on the market, but come with a considerable financial expense, and are relatively large and complex in setup.

#### B. Synchronisation using GPS Signals

The global positioning system (GPS) provides a time radio signal which is available worldwide and accurate to several nanoseconds. It can therefore also serve as an accurate frequency and clock reference [8]. Select off-the-shelf GPS receivers output a so-called 1PPS (one pulse per second) signal. The signal is a 20 ms pulse train with a rate of 1 Hz. The rising edge of each pulse is synchronised with the start of each GPS and UTC (coordinated universal time) second with an error of less than  $1 \mu s$ . This accuracy is in general more than sufficient for serving as clock reference for a baseband measurement system.

To the authors' knowledge no battery-powered portable audio player/recorder with an external synchronisation input is currently available on the market. As a consequence, direct synchronisation between the transmitter and the receiver-side

is in our application again not possible, even though a suitable clock reference signal would be available.

We propose in the remainder of this section a measurement method and setup with which synchronisation can nevertheless be achieved by recording the clock reference signal in parallel to the received and transmitted signals and appropriate post-processing.

#### C. Hardware Setup

On the aircraft, the signals are transmitted and received via the aircraft-integrated VHF transceiver. The measurement audio signal is replayed by a portable CompactFlash-based audio player/recorder [9]. The transmitted and received signals are recorded with a second unit, in parallel with the 1PPS synchronisation signal which is provided by the GPS module [10]. The aircraft position, altitude, speed, heading, etc., are accurately recorded by a hand-held GPS receiver once every two seconds [11]. The setup is portable, battery-powered, rigid, and can be easily integrated into any aircraft. The only requirement is a connection to the aircraft radio headset connectors. Figure 2 shows the final hardware setup on-board the aircraft. An identical setup is used on the ground,



Fig. 2. Complete voice channel measurement system on-board an aircraft, with audio player and recorder, interface box, synchronisation GPS (top left), and tracking GPS (bottom right).

All devices are interconnected in a star-shaped manner through a custom-built interface box, which is fitted into a metal housing unit containing some passive circuitry and standard XLR and TRS connectors (Fig. 3). The interface box provides a push-to-talk (PTT) switch remote control together with status indication and recording, and power supply, status indication and configuration interface for the GPS receiver. The box serves as the central connection point and provides potentiometers for signal level adjustments, test points for calibration and a switch to select transmit or receive signal routing. The design considers the necessary blocking of the microphone power supply voltage, the appropriate shielding and ground for electromagnetic compatibility (EMC) as well as noise and cross-talk suppression.

#### D. Measurement Signal

The measurement signal consists of a continuously repeated binary maximum length sequence (MLS) of length  $L=63$

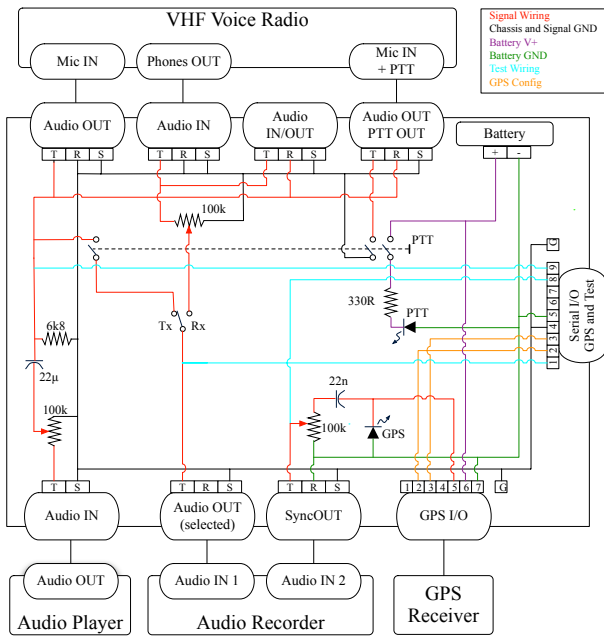

Fig. 3. Overview and circuit diagram of measurement system and interface box.

samples or  $T = 7.875$  ms at a chip rate of 8 kHz [12]. This length promises a good trade-off between signal-to-noise ratio, frequency resolution and time resolution. It results in an MLS frame repetition rate of 127 Hz and an excitation of the channel with a white pseudo-random noise signal with energy up to 4 kHz. The anticipated rate of channel variation at the given maximum aircraft speed and the bandwidth of the channel are below these values [6].

The transmitted MLS sequence is interrupted once per minute by pre-computed dual tone multi frequency (DTMF) tone pairs, in order to ease rough synchronisation between transmitted and received signals. All audio files are played and recorded at a sampling rate of 48 kHz and with a resolution of 16 bit. The measurement signal is therefore upsampled to 48 kHz by zero-padding and low-pass interpolation with a symmetric FIR filter (using Matlab's `interp`-function). The signal is continuously transmitted during the measurements. However, small interruptions are made every 30 seconds and every couple of minutes due to technical and operational constraints.

### E. Data Processing

The post-processing of the recorded material consists of data merging, alignment, synchronisation, processing and annotation and is mostly automated in Matlab. The aim is to build up a database of annotated channel measurements which is described in IV. The following section outlines the different processing steps.

1) *Incorporation of Side Information:* The original files are manually sorted into a directory structure and labelled with an approximate time-stamp. The handwritten notes about scenarios, the transmission directions, the corresponding files,

the time-stamps and durations are transferred into a data structure to facilitate automatic processing. Based on the data structure, the start time of each file is estimated.

The GPS data is provided in the widely used GPX-format and is imported into Matlab by parsing the corresponding XML structure, from which longitude, latitude, altitude and time-stamp can be extracted [13]. The remaining parameters are computed out of these values, also considering the GPS coordinates of the airport tower. The speed values are smoothed over time using robust local regression smoothing with the RLOESS method with a span of ten values or 20 s [14].

2) *Analysis of 1PPS Signal and Sampling Rate:* The recorded files are converted into Matlab-readable one-channel wave files using a PRAAT script [15]. From the 1PPS recording, the positions of the pulses are identified by picking the local maximum values of a correlation with a prototype shape. As it is known that the pulses are roughly one second apart, false hits can be removed, and missing pulses can be restored by interpolation. The time difference in samples between two adjacent pulses defines the *effective* sampling rate at which the file was recorded. It was found that the sampling rate is fairly constant but varies among the different devices by several Hertz. It is therefore necessary to compensate for the clock rate differences. For the aircraft and ground recordings, the sampling rate can be recovered by means of the 1PPS track. Based on those the sampling rate of the audio *player* can also be estimated.

3) *Detection of DTMF Tones and Offset:* For detecting the DTMF tones, the non-uniform discrete Fourier transform (NDFT) is computed at the specific frequencies of the DTMF tones [16]. The tones are detected in the power spectrum of the NDFT by correlation with a prototype shape, as the duration and relative position of the tones is known from the input signal. Again after filtering for false hits, the actual DTMF symbol is determined by the maxima of the NDFT output values at the corresponding position. The detected DTMF sequences of corresponding air/ground recording pairs are then aligned with approximate string matching using the Edit distance measure [17]. Their average offset in samples is computed and verified with the offset that is obtained from the data structure with the manual annotations. These rough offsets are refined using the more accurate 1PPS positions of both recordings.

4) *Frame Segmentation and Channel Response:* The recording of the received signal is split up into segments or frames of 378 samples, which is the length of one MLS. The corresponding frame in the recording of the transmitted signal is found by the previously computed time-variant offsets between the 1PPS locations in the two recordings, and then with the local position in-between two 1PPS pulses. Through this alignment the synchronisation between transmitted and recorded signal is reestablished. The alignment is accurate to one 48 kHz sample, which is sufficient, since the original MLS sequence had a sampling rate of 8 kHz and is only oversampled to 48 kHz.

The frequency or channel impulse response is then com-

puted using spectral division or cross-correlation between channel input and output. The frames are annotated with the flight parameters and the contextual information from the above data structure using the previously computed time-stamps and offsets.

### III. CONDUCTED MEASUREMENTS

A number of ground-based and in-flight measurements were undertaken with a general aviation aircraft at and around the Punitz airfield in Austria (airport code LOGG). After initial trials at the end of March 2006, measurements were undertaken for two days in May 2006. The aircraft used was a 4-seat Cessna F172K with a maximum speed of approximately 70 m/s and a Bendix/King KX 125 TSO communications transceiver (Fig. 4). The initial trials were undertaken with a different aircraft.



Fig. 4. General aviation aircraft type Cessna F172K during channel measurements.

On ground, the communications transceiver Becker AR 2808/25 was used. It is permanently installed in the airport tower in a fixed frequency configuration.

For reference and comparison, a Rohde&Schwarz EM-550 monitoring receiver which provides I/Q demodulation of the received AM signal was applied. The I/Q data with a bandwidth of 12 kHz was digitally recorded onto a laptop computer, however without a 1PPS synchronisation signal. Synchronisation is to a certain extent nevertheless possible using the DTMF markers in the transmitted signal. For the monitoring receiver a  $\frac{\lambda}{4}$ -ground plane antenna with a magnetic base was mounted onto the roof of a van.

The measurements occurred on the AM voice radio channel of Punitz airport at a carrier frequency of 123.20 MHz. Measurements were taken both in uplink and downlink direction, with the tower or the aircraft radio transmitting, respectively. The I/Q monitoring receiver continuously recorded every transmission.

A series of measurement scenarios was set up which covered numerous situations. The *ground* measurements consisted of static back-to-back measurements with the aircraft engine on and off. Static measurements were undertaken with the aircraft at several positions along a straight line towards the tower, spaced out by 30 cm. Additional measurements were taken with a vehicle parked next to the aircraft. The ground based measurements were concluded with the rolling of the aircraft

on the paved runway at different speeds. A variety of *flight manoeuvres* was undertaken. These covered the following situations and parameter ranges:

- Low and high altitudes (0m to 1200m above ground)
- Low and high speeds (up to 250 km/h)
- Ascends and descends
- Headings perpendicular and parallel to line-of-sight
- Overflights and circular flights around airport
- Take-offs, landings, approaches and overshoots
- Flights across, along and behind a mountain
- Flights in areas with poor radio reception (no line-of-sight)

Thorough organisational planning, coordination and cooperation between all parties involved proved to be crucial for a successful accomplishment of measurements in the aeronautical environment.

### IV. THE TUG-EEC-Channels DATABASE

Based on the above measurements Graz University of Technology (TUG) and Eurocontrol Experimental Centre (EEC) present an aeronautical voice radio channel database, the *TUG-EEC-Channels*. It is available to the research community under a public licence free of charge online at the following address: <http://www.spsc.TUGraz.at/TUG-EEC-Channels/>

The *TUG-EEC-Channels* cover the channel measurements described in Sec. III with three extensive flights and several ground measurements with a total duration of more than five hours or two million MLS frames. For each frame of 8 ms (corresponding 378 samples at 48 kHz) the following data and annotation is provided:

- Time-stamp
- Transmission recording segment
- Reception recording segment
- I/Q recording segment
- Link to original sequence
- Uplink/downlink direction
- Estimated channel impulse response
- Flight parameters elevation, latitude, longitude, distance to tower, speed, and azimuth relative to line-of-sight
- Plain-text comments

Furthermore, *TUG-EEC-Channels* includes a number of voice signal transmission recordings, as well as voice and background noise recordings made in the cockpit using conventional and avionic headset microphones. Upon request, the raw MLS recordings can also be provided. An exact description of the data format of the *TUG-EEC-Channels* and additional information can be found on the website.

The figures on the next page present several excerpts of the database. Figure 5 shows the magnitude response of the transmission chain in both directions, which is mostly determined by the radio transceivers. In Fig. 6, the magnitudes of selected frequency bins of the downlink channel are plotted over time. The basic shape of the frequency response is maintained, but the magnitude varies over time and flat fading occurs. Further analysis will show if flat fading is the dominating effect on the channel. Fig. 7 illustrates a GPS track.

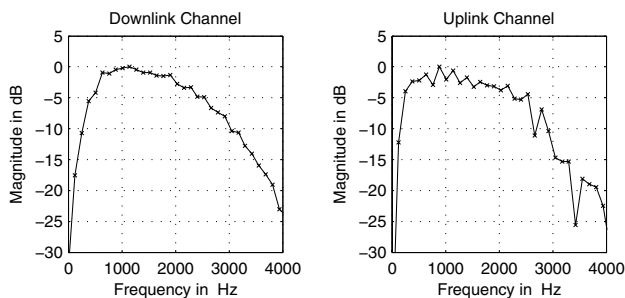

Fig. 5. Normalised frequency response of the static back-to-back voice radio channel in up- and downlink direction.

## V. CONCLUSION

A system for channel measurements and the *TUG-EEC-Channels* database of annotated channel impulse and frequency responses for the aeronautical VHF voice channel is provided. The current data can be directly applied to simulate a transmission channel for system test and evaluation. We expect that the aeronautics community will make extensive use of our data for future developments, which would also help to verify the validity of our measurement scenarios.

Beyond that, it would be interesting to see what conclusions with respect to parameters of the aeronautical radio channel models can be drawn from the data. Our future work will include further analysis and abstraction of the data in order to build a model of the aeronautical VHF voice channel.

## ACKNOWLEDGMENTS

The authors are grateful to FH JOANNEUM (Graz, Austria), and Dr. Holger Flühr and Gernot Knoll in particular, for taking charge of the local organisation of the measurements. We also want to thank the Union Sportfliegerclub Punitz for the kind permission to use their facilities, Flyers GmbH and Steirische Motorflugunion for providing the aircraft, and Rohde & Schwarz for contributing the monitoring receiver.

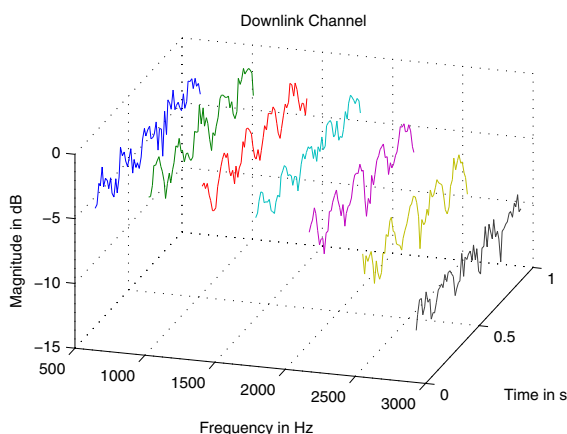

Fig. 6. Evolution of the frequency bins at 635, 1016, 1397, 1778, 2159, 2540 and 2921 Hz over time. Aircraft speed is  $44.7 \frac{\text{m}}{\text{s}}$  at a position far behind the mountain and an altitude of 1156 m.

Finally, we want to recognise all the other parties that helped to make the measurements possible. The campaign was funded by EUROCONTROL Experimental Centre (France).

## REFERENCES

- [1] D. van Roosbroek, "EATMP communications strategy," Eurocontrol, Technical Description Vol. 2 (Ed. 6.0), 2006.
- [2] M. Hagmüller, H. Hering, A. Kröpfl, and G. Kubin, "Speech watermarking for air traffic control," in *Proceedings of the 12th European Signal Processing Conference (EUSIPCO'04)*, Vienna, Austria, September 2004.
- [3] K. Hofbauer and H. Hering, "Digital signatures for the analogue radio," in *Proceedings of the 5th NASA Integrated Communications Navigation and Surveillance Conference (ICNS)*, Fairfax, USA, May 2005.
- [4] M. Pätzold, *Mobile Fading Channels. Modelling, Analysis and Simulation*. John Wiley and Sons Ltd., 2002.
- [5] J. D. Parsons, *The Mobile Radio Propagation Channel*. John Wiley and Sons Ltd., 2000.
- [6] K. Hofbauer and G. Kubin, "Aeronautical voice radio channel modelling and simulation—a tutorial review," in *Proceedings of the 2nd International Conference on Research in Air Transportation (ICRAT 2006)*, Belgrade, Serbia, July 2006.
- [7] BAE Systems Operations Ltd, "Literature review on terrestrial broadband VHF radio channel models," B-VHF, Report D-15, 2005. [Online]. Available: <http://www.B-VHF.org>
- [8] D. W. Allan, N. Ashby, and C. C. Hodge, "The science of timekeeping," Agilent Technologies, Application Note AN 1289, 2000.
- [9] M-Audio. (2005) MicroTrack 24/96 user guide. [Online]. Available: <http://www.m-audio.com>
- [10] Garmin. (2000) GPS 35-LVS technical specification. [Online]. Available: <http://www.garmin.com>
- [11] —. (2005) eTrex Legend owner's manual and reference guide. [Online]. Available: <http://www.garmin.com>
- [12] B. Sklar, *Digital Communications*, 2nd ed. Prentice-Hall, 2001.
- [13] TopoGrafix. (2006) GPX: the GPS exchange format. [Online]. Available: <http://www.topografix.com/gpx.asp>
- [14] W. S. Cleveland and S. J. Devlin, "Locally-weighted regression: An approach to regression analysis by local fitting," *Journal of the American Statistical Association*, vol. 83, pp. 596–610, 1988.
- [15] P. Boersma and D. Weenink. (2006) PRAAT: doing phonetics by computer [computer program]. [Online]. Available: <http://www.praat.org/>
- [16] M. D. Felder, J. C. Mason, and B. L. Evans, "Efficient dual-tone multifrequency detection using the nonuniform discrete fourier transform," *IEEE Signal Processing Letters*, vol. 5, no. 7, July 1998.
- [17] P. A. V. Hall and G. R. Dowling, "Approximate string matching," *ACM Computing Surveys*, vol. 12, no. 4, 1980.

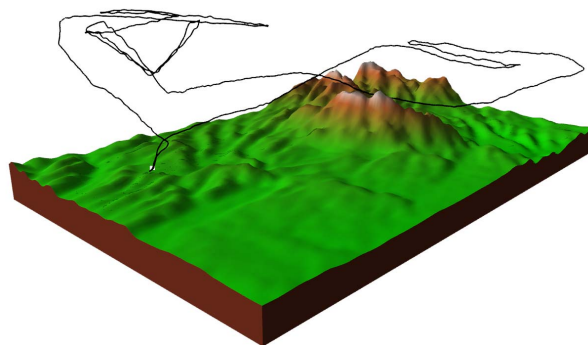

Fig. 7. Visualisation of the aircraft track based on the recorded GPS data.