

AM 2025 – Wohin geht die Reise in der Additiven Fertigung mit den neuen Verfahren „SAT-3D“ und „SLEDM“

Univ.-Prof. Dipl.-Ing. Dr.techn. **Franz Haas**

Dipl.-Ing. **Patrick Aschauer**

Institute of Production Engineering (IFT), Graz University of Technology

Agenda

- **Initial Situation**
- Invention → Prototyping “SAT-3D”
- Invention → Production “SLEDM”
- LED vs. Laser/Electron Beam
- Design Process
- Summary and Outlook

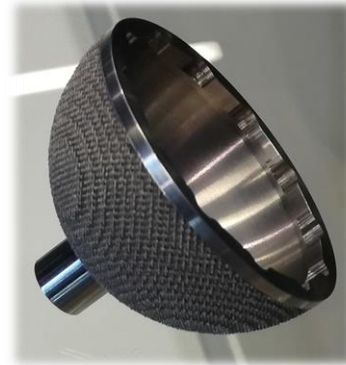

IFT - Competence Portfolio

Precision Machining

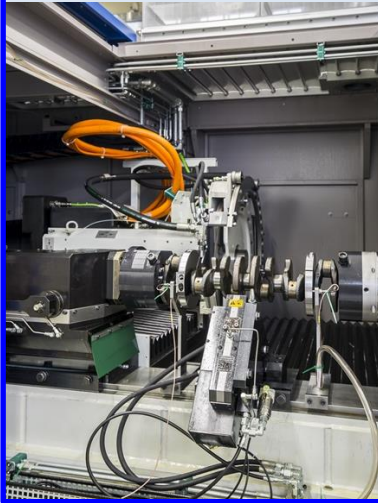

Fluid Technology



Additive Manufacturing



Smart Factory



Process Chain and our Mission

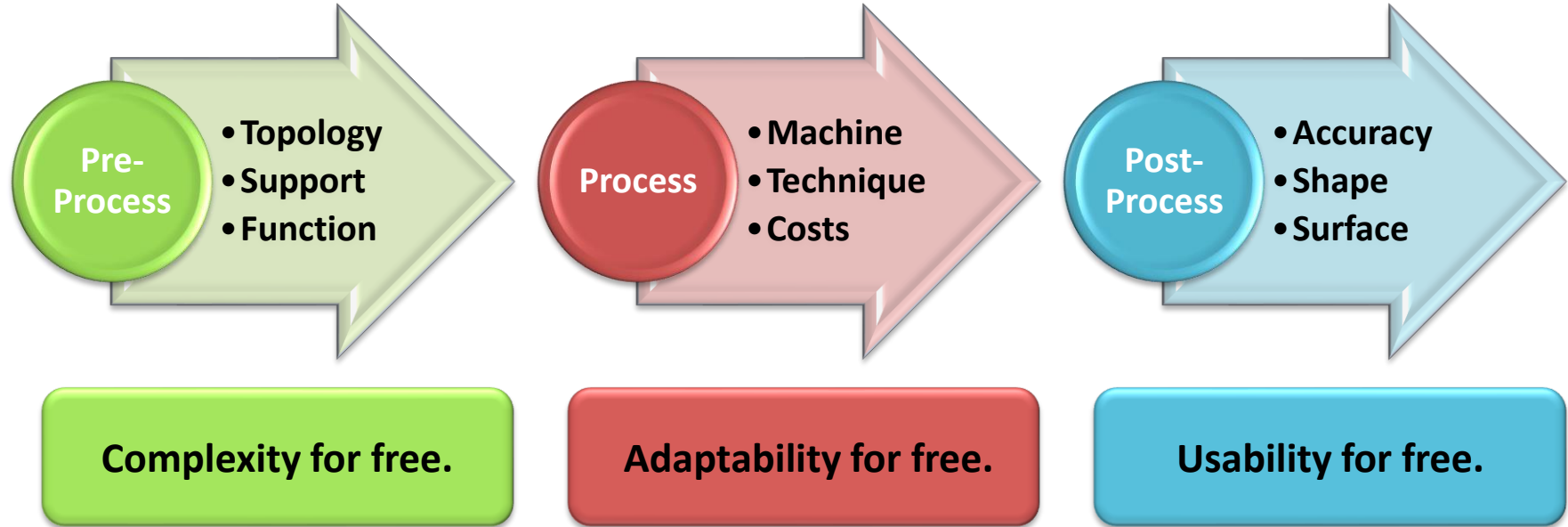

Limitations until now



Production Time

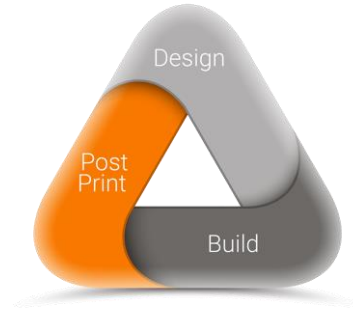

Post Processing



Machine Costs



AM is still not established in mass production.

Agenda

- Initial Situation
- **Invention → Prototyping “SAT-3D”**
- Invention → Production “SLEDM”
- LED vs. Laser/Electron Beam
- Design Process
- Summary and Outlook



Source: <https://cypherbits.net>

SAT-3D (Natriumacetat Trihydrat)

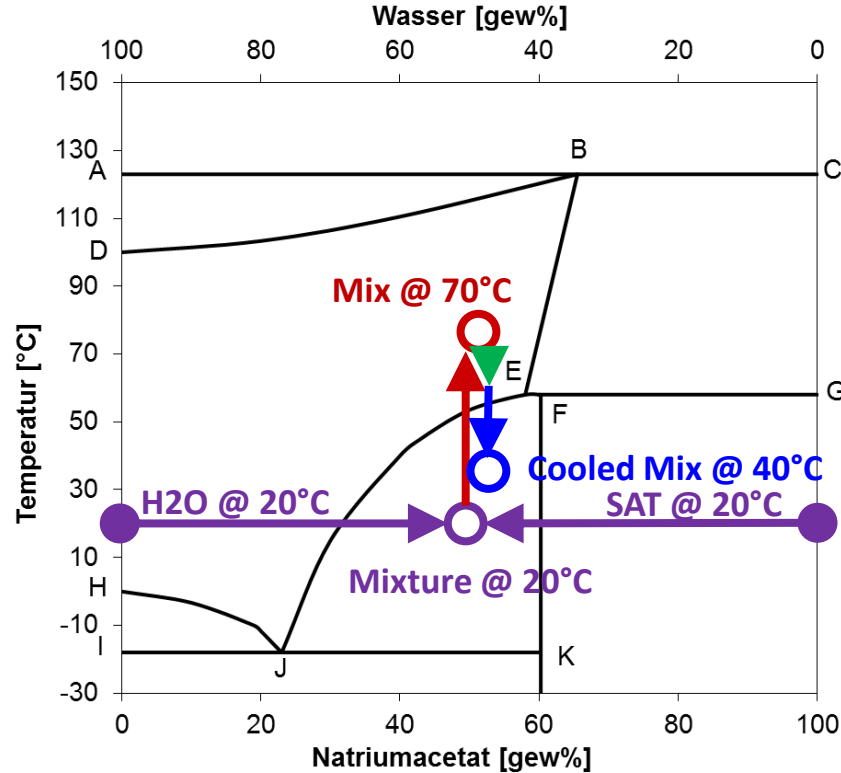

Process Steps:

- Mixture
- Heating
- Transportation
- Cooling
- Printing

Patent and Results

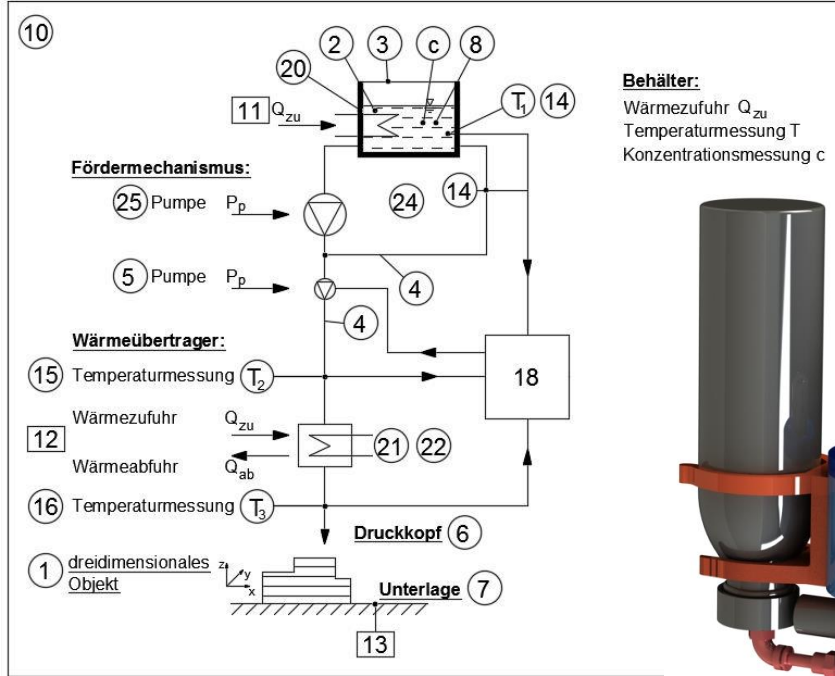

Agenda

- Initial Situation
- Invention → Prototyping “SAT-3D”
- **Invention → Production “SLEDM”**
- LED vs. Laser/Electron Beam
- Design Process
- Summary and Outlook



Source: <https://cypherbits.net>

Change in Metal Additive Manufacturing

From Laser (SLM)

to LED (SLED^M)

Invention - SLEDM

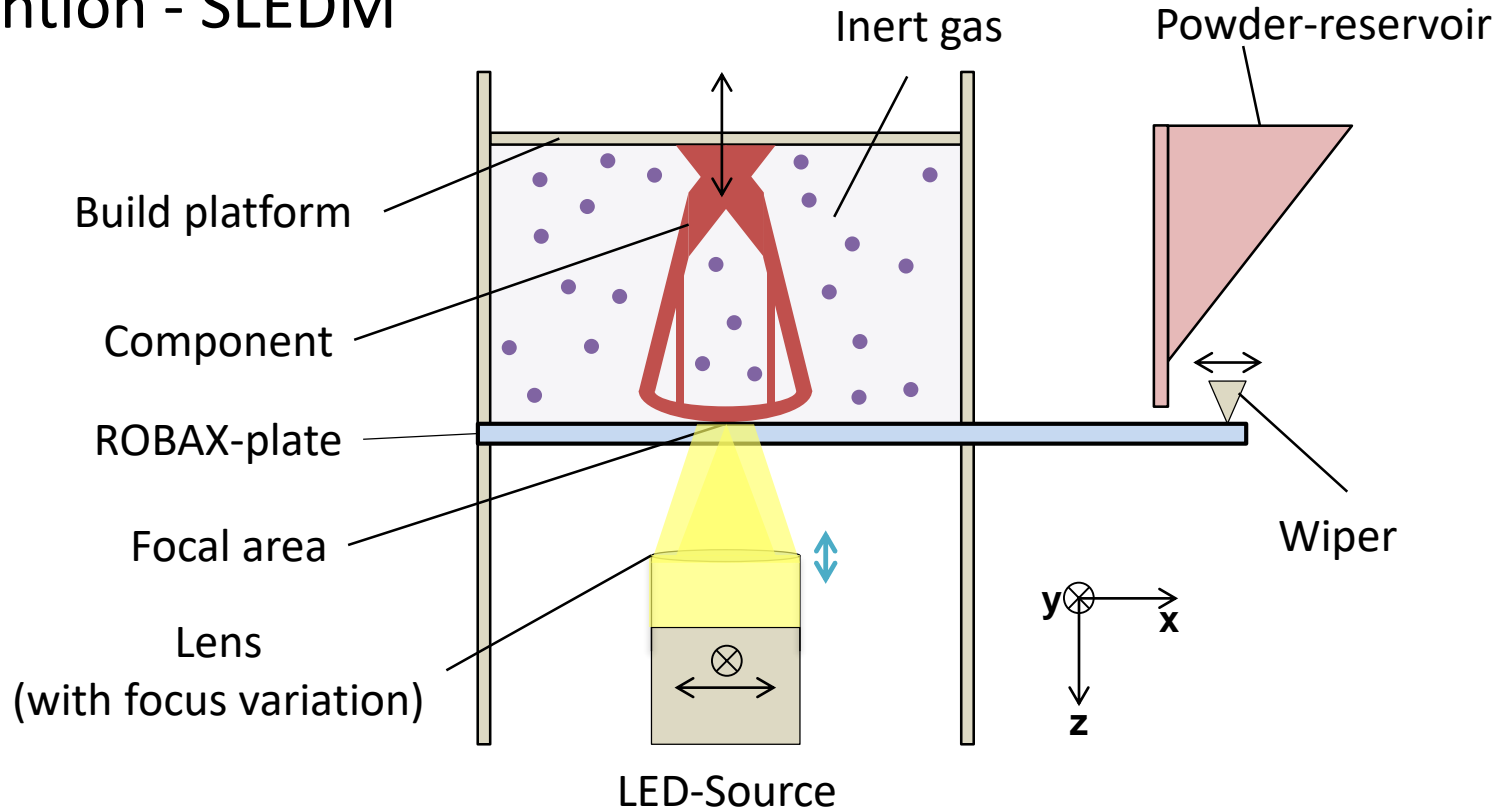

Principle with more details

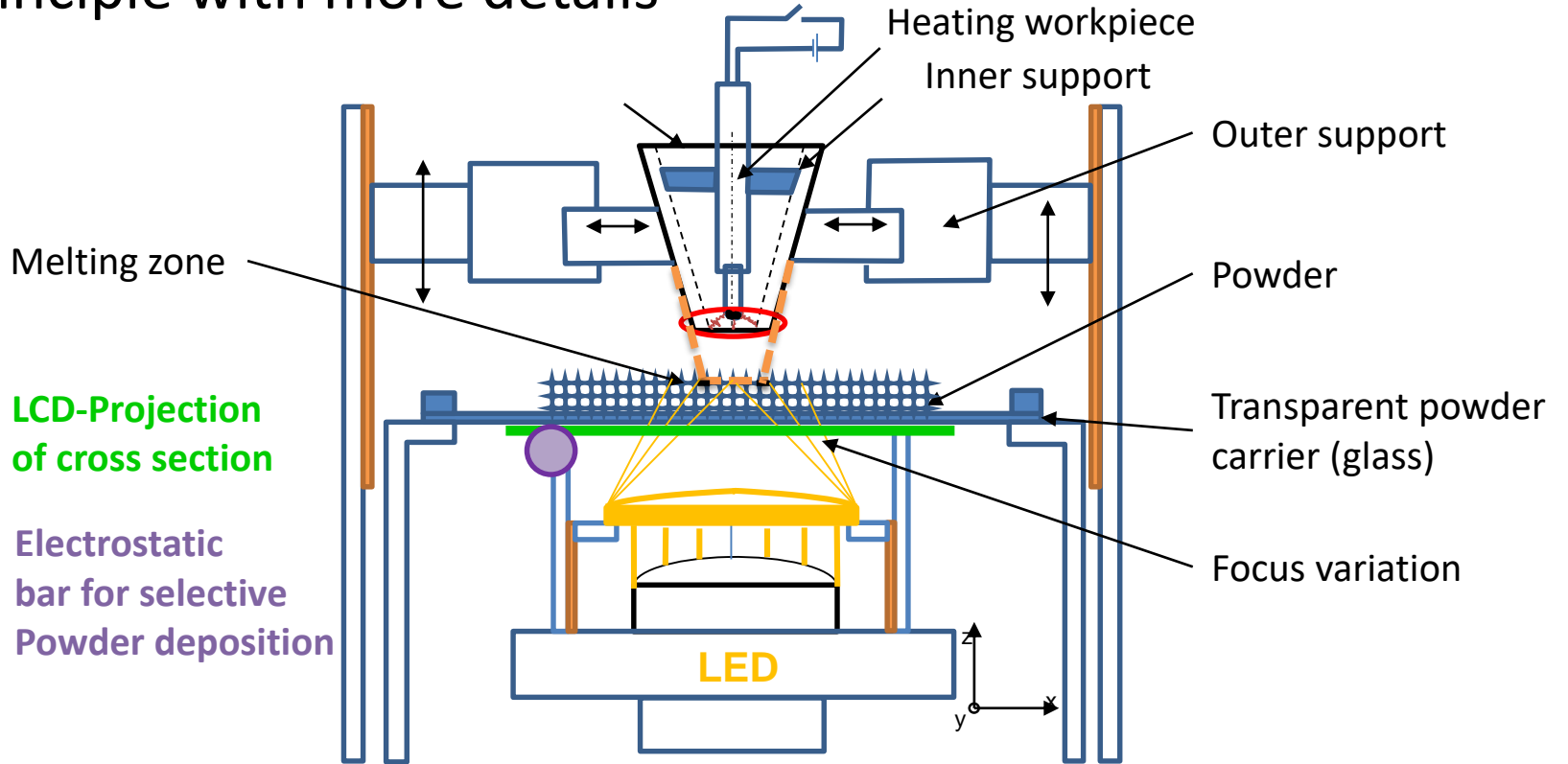

Agenda

- Initial Situation
- Invention → Prototyping “SAT-3D”
- Invention → Production “SLEDM”
- **LED vs. Laser/Electron Beam**
- Design Process
- Summary and Outlook

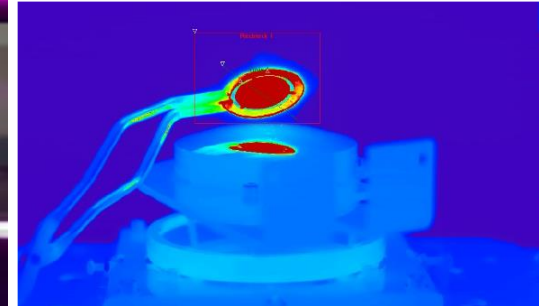
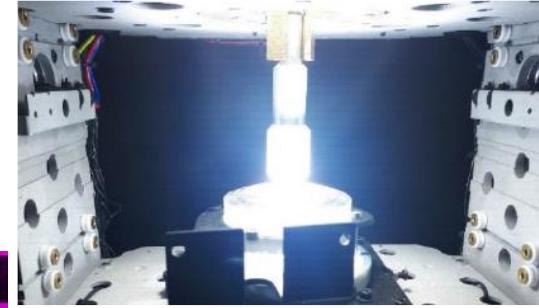
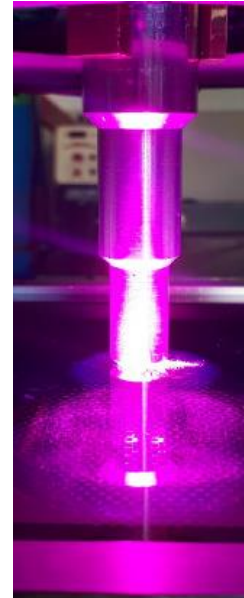

LED vs. Laser/Electron Beam

SLEDM	Characteristic	Laser/Electron Beam
LED	Energy Source	Laser, Electron
Variable (200 μm up to 20 mm)	Melting Spot	Constant (e.g. 90 μm)
Top-Down	Building Direction	Down-Top
Linear Direction LED	Scanning Device	Mirror/Deflection System

SLEDM – Technical Advantage



Safety

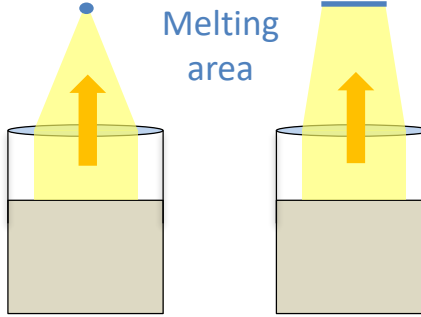

Variable melting area



Time & costs



Low active powder volume

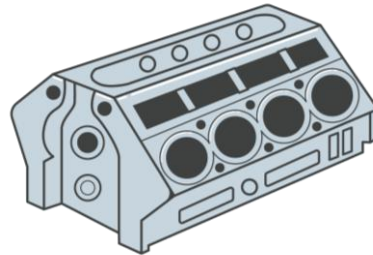

Powder handling



Ready for mass production

Agenda

- Initial Situation
- Invention → Prototyping “SAT-3D”
- Invention → Production “SLEDM”
- LED vs. Laser/Electron Beam
- **Design Process**
- Summary and Outlook

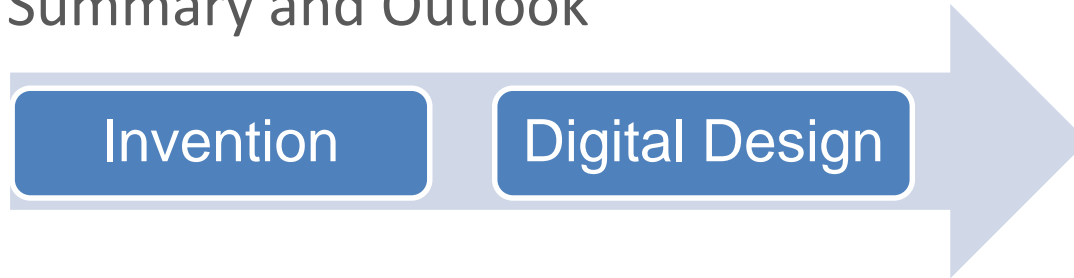

Design Process



Top

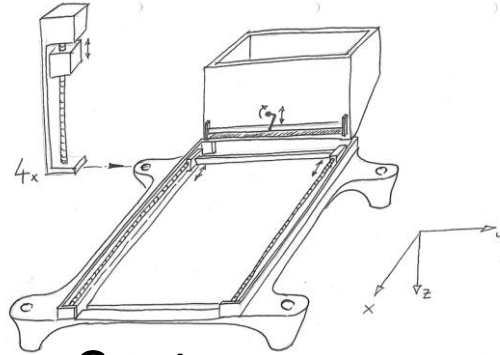

Centre

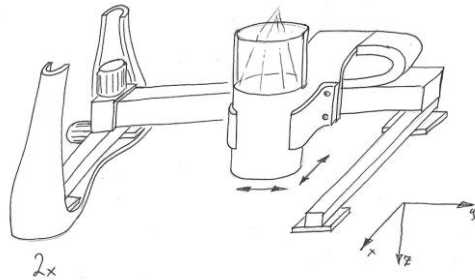

Bottom

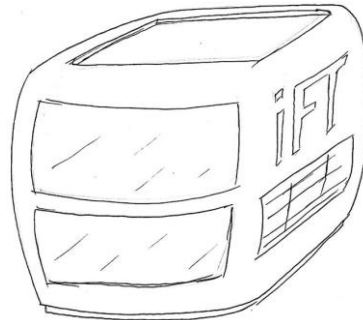

Housing

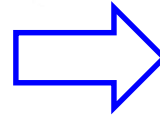

Final product



SLEDM – Assemblies

Assemblies

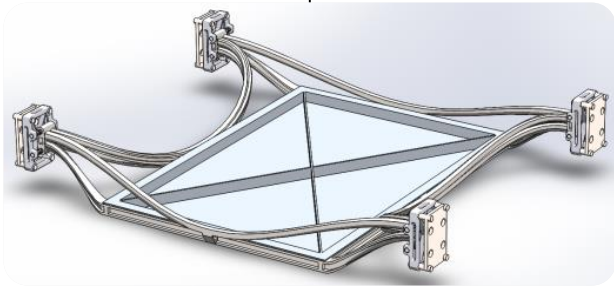

Top

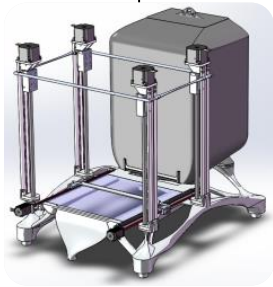

Centre

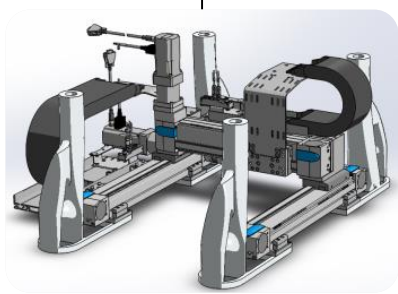

Bottom

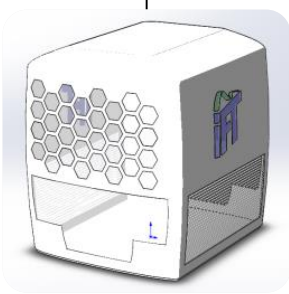

Housing

FEM-Analyses

Topology Optimization

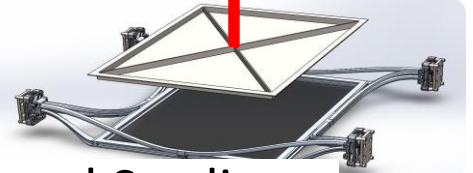
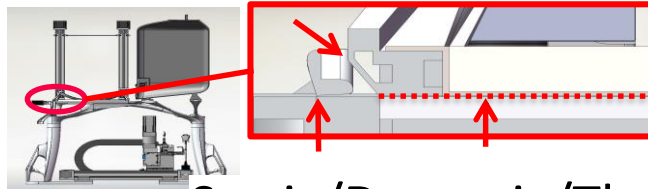
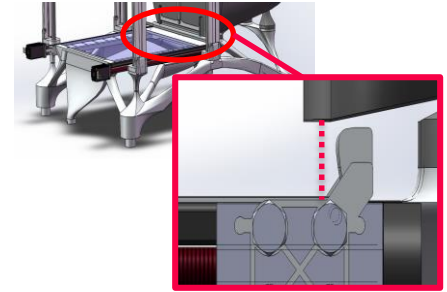
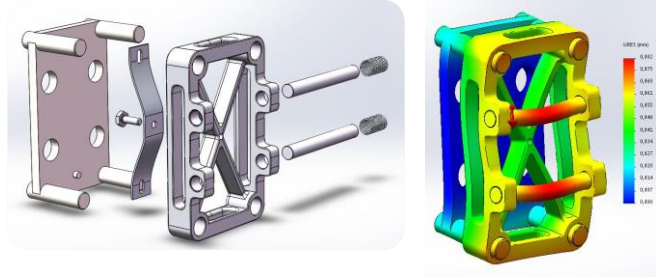
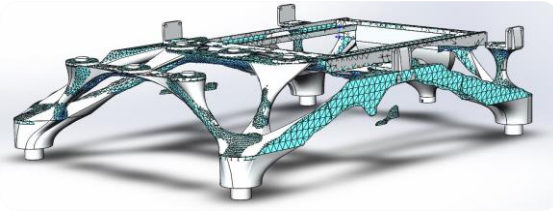

Static/Dynamic/Thermal Studies

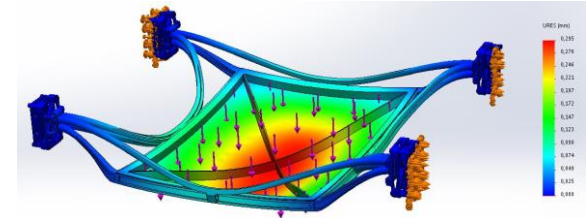
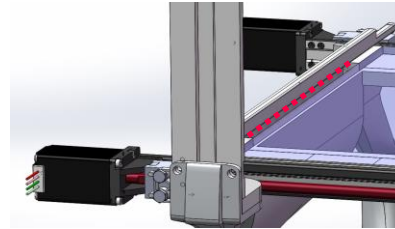
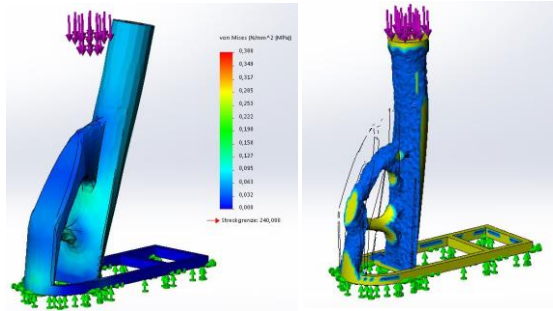

SLEDM – Construction

Assemblies

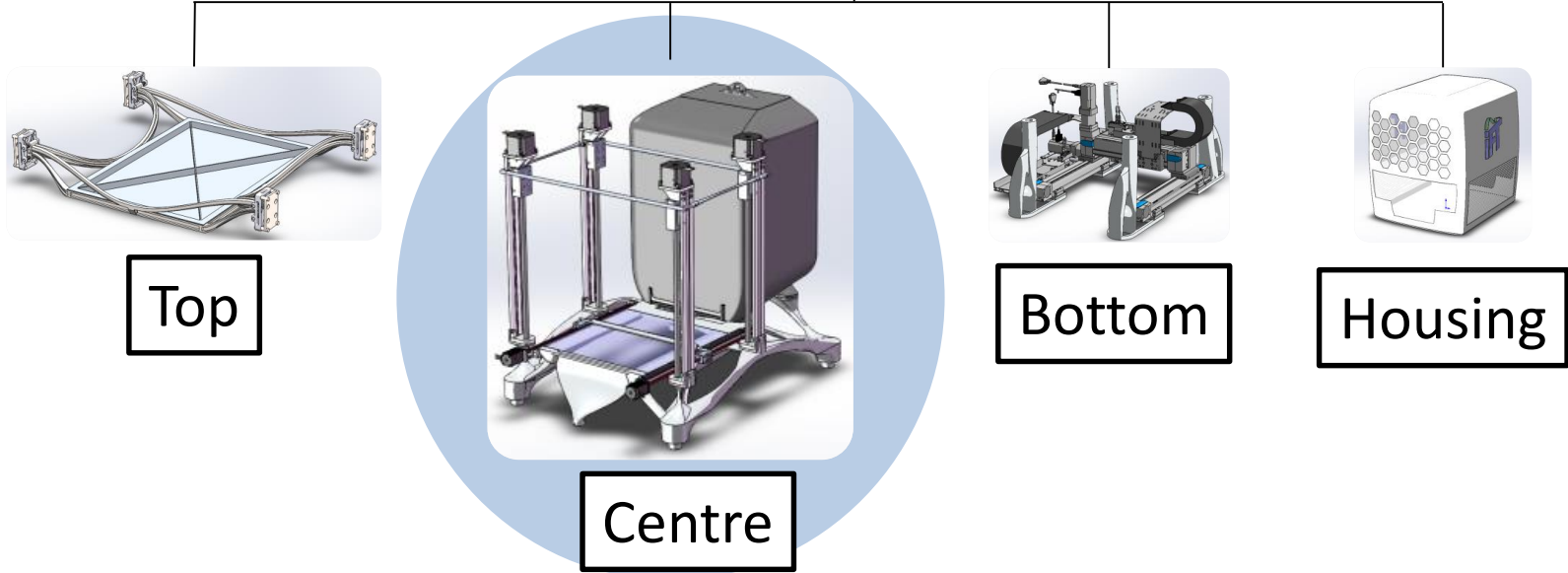

Thermal Management - Centre

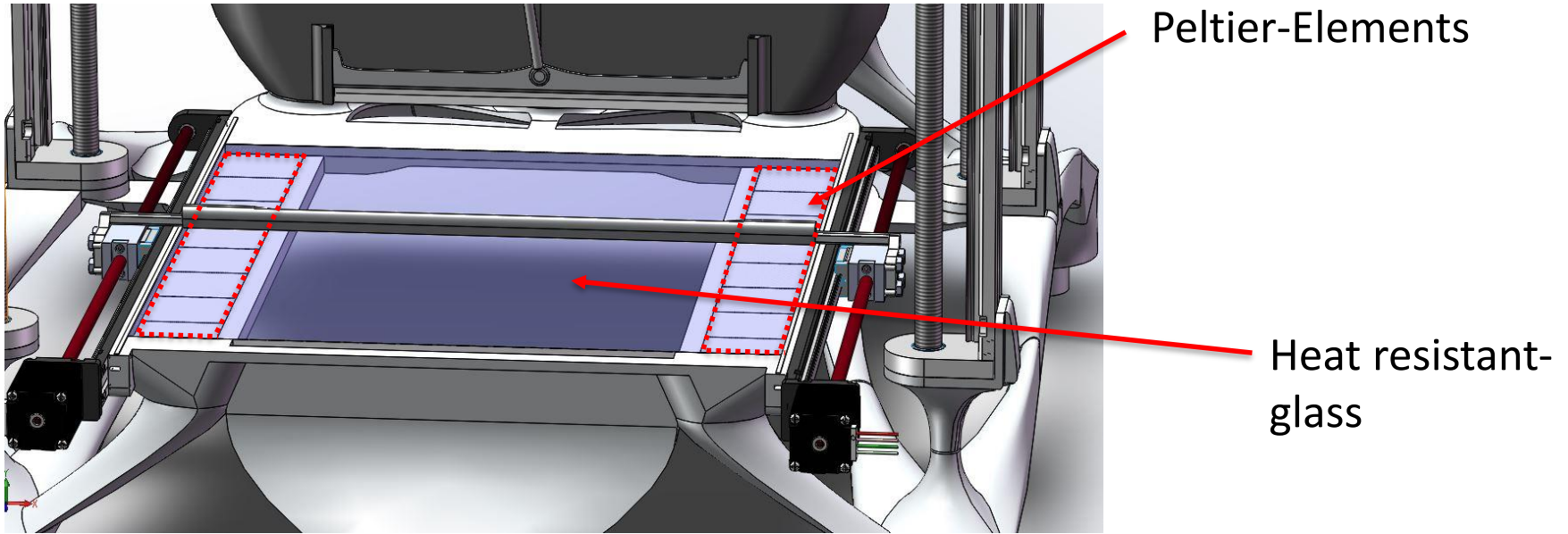

Temperature Measurements

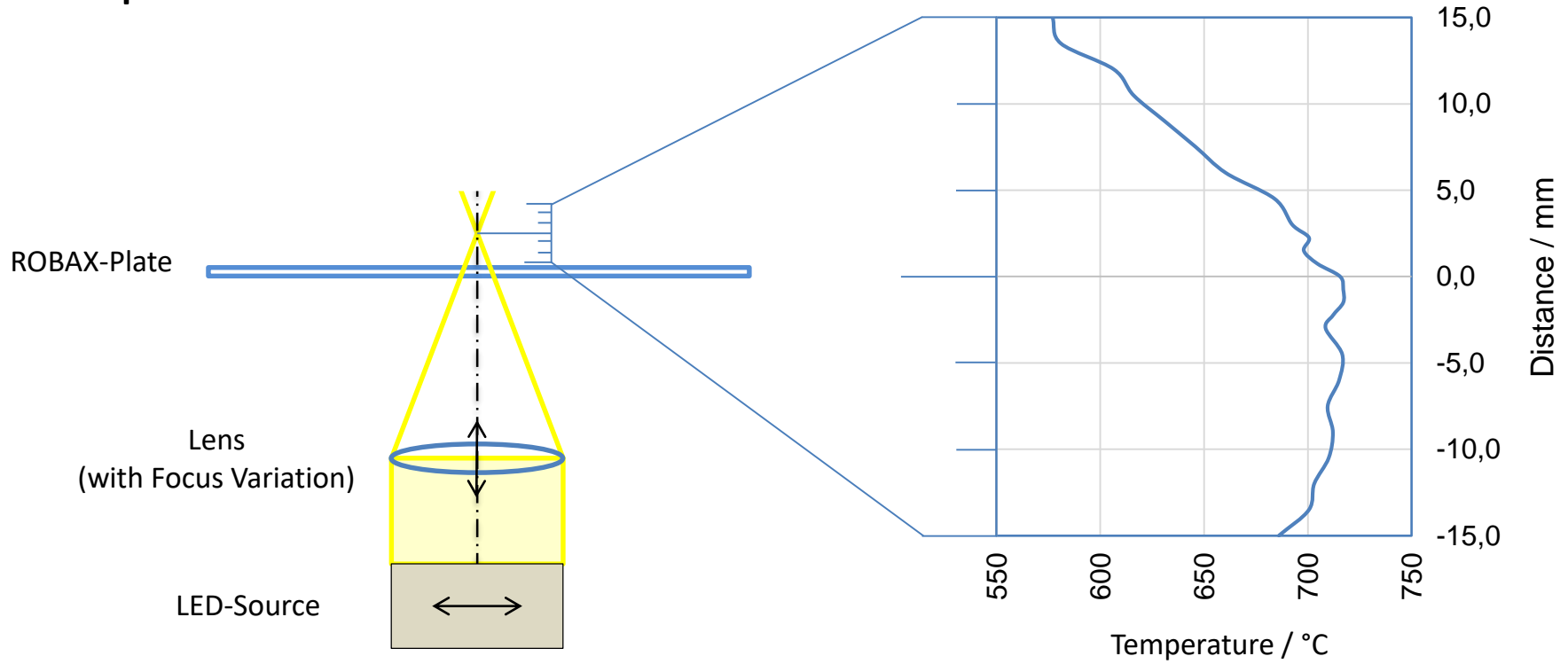

SLEDM-Prototype



Summery and Outlook

Patent application
done

Scientific work

Publications

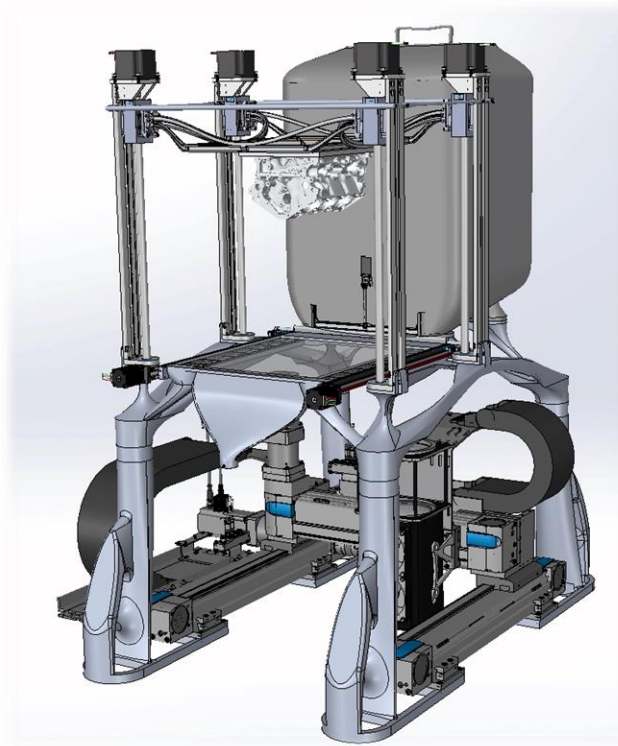

Tests with different
powders

Collaboration with
industry

Standardization