

CAE for high performance in-feed processes at sorting systems

Christian LANDSCHÜTZER^{1,*}, Andreas WOLFSCHLUCKNER², Dirk JODIN³

¹⁾ Ass.Prof. Dipl.-Ing. Dr.techn., TU Graz, Institute of Logistics Engineering, Graz, Austria

²⁾ Dipl.-Ing., PhD candidate, TU Graz, Institute of Logistics Engineering, Graz, Austria

³⁾ Univ.-Prof. Dr.-Ing. habil., head of Institute, TU Graz, Institute of Logistics Engineering, Graz, Austria

Abstract: This paper concludes the first steps for CAE with sorting systems from ICMaS'12. As high performance sorting processes are more and more relevant not only but very much from e-commerce business engineering is addressed to bring faster, more accurate and safer technologies therein.

The authors describe the in-feed-process, identified as a crucial one for extending sorter performance. An analytical solution (2D) for the "classic" belt feeder is presented and compared with a multibody model. Valuable insights for modelling, effort and practical use are demonstrated. A MBD-simulation is presented and an overview shows where and how to adjust the design from simulation findings.

Key words: CAE, Multi Body Dynamics/Simulation (MBD, MBS), sortation system, tilt tray sorter, in feed process, design optimization, design of experiments.

1. INTRODUCTION

Within highly competitive markets nearly every branch based on engineering in whatever way to think successful providers of solutions and products are demanded to improve product quality and lower costs more than competitors. Those different branches, like automotive, aerospace, general machinery and logistics engineering or material handling equipment design have found more or less optimal solutions, to handle these demands in various ways.

Looking about design methodologies and engineering or product development guidelines [7, 8, 9], subsuming over several different approaches one can identify a clear trend to:

- Parallelize engineering tasks
- Transferring time consuming calculation and simulation task to an early stage in product development (frontloading) to manage costs

altogether named as simultaneous engineering (SE) as shown in a comprehensive view in Fig. 1.

Product development has a clear vision for valid function of the product, which can only be secured in a very late state i.e. detailed design or development (Fig. 1). As building test stands, to verify product functions is depending very much on the final geometry of the product – which is itself a result of the overall design process – is very time consuming and expensive and therefore not easily to adapt, one has to find other ways to demonstrate and examine product function.

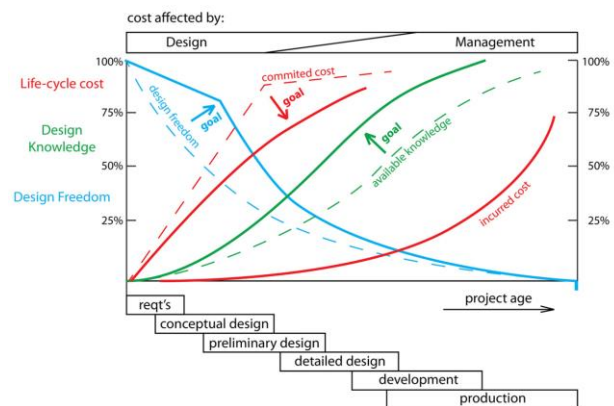

Fig. 1. Product Development Process (PEP) with overlapping phases (SE) [2].

Therefore Computer-Aided-Engineering Methods (CAE) are widely spread over the engineering branches as a common way to deal with demands mentioned above. A few key performance indicators can be identified, describing CAE in engineering:

- Highly adaptable modelling (geometry, mechanical parameters)
- Various different ways, to “examine” and use a model by scaling sizes and varying parameters; Design of Experiments (DoE).
- Once basic knowledge is achieved and a model library is established short and inexpensive development of models can be possible.

* Corresponding author:
 Graz University of Technology, Institute of Logistics Engineering,
 Inffeldgasse 25e, 8010 Graz, AUSTRIA,
 Tel.: +43 316 873 7325
 Fax: +43 316 873 107325

E-mail addresses:
 landschuetzer@tugraz.at (C. Landschützer),
 wolfschluckner@tugraz.at (A. Wolfschluckner),
 dirk.jodin@tugraz.at (D. Jodin).

Material Handling and Logistics Engineering is not so much driven by virtual engineering as i.e. automotive development. But the impact in reducing test stands, by generating models, simulations and DoE, is quite large, as the test installations are highly complex and not easy to adjust in its parameters. So the authors and the whole Institute of Logistics Engineering at Graz University of Technology (ITL) have a clear vision, to empower material handling engineering tasks with CAE technology. A conveyor-toolbox is actual state of research, where some details have been presented at ICMA'S'12 [6] and is concluded within this work focusing on the in-feed-process in sortation systems and general material handling devices.

2. The Sortation System and the in-feed

With higher volumes in parcel and piece goods distribution performance of sorting systems is increasing continuously. Those highly engineered products are touching limits of physics, achieving i.e. centripetal forces and frictions hard on the limit. Therefore there is a necessity of CAE and DoE specially for new technologies and high performance systems. With varying throughput, speed, variety of goods the field for CAE and DoE is defined clearly.

A short description of sortation systems helps to understand the overall vision [6]. Sortation systems are found in various installations: Baggage handling in airports, distribution of parcels, mail order business, etc. The core of a sortation system is the sorter itself (fig. 2), which distributes goods to their specified accumulation area.

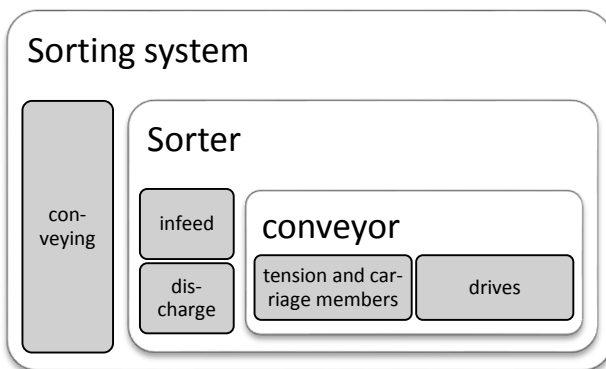

Fig. 2. A sorting system installation – mechanical view without identification and control [1].

Different types of sorting systems are used like Line sorters, loop sorters or ring sorters. In general a sortation system is sub-divided in five different parts (fig. 3):

- 1: In-feed or induction: goods/parcels enter sorting system
- 2: Preparation: goods/parcels get separated and oriented
- 3: Identification: scanner identify goods/parcels and read out their destination
- 4: Sorter: goods are distributed to their allocated output
- 5: Accumulation area (Discharging): goods leave the sorting system

In this paper the authors focus on the sorter itself and here on the in-feed process, where the ICMA'S'12 contribution focused the discharging with tilt-tray-sorters [6]. For details of other parts the reader may refer to literature [1].

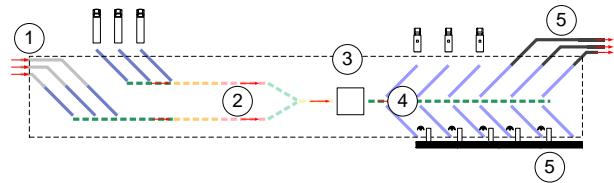

Fig. 3. Sortation system [1, 6].

Various different ways to design the automated in-feed have been developed from those few successful manufacturers where Fig. 4 gives an overview.

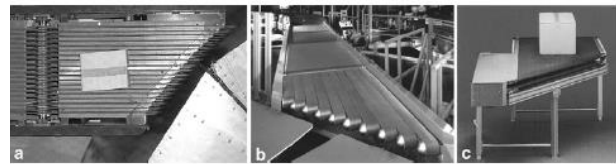

Fig. 4. In-feed, mechanical solutions: a round belts, b stripe belts, c flexible angled-belt [1].

The main task for the in-feed process is to secure

- a precise position
- a precise orientation
- the right speed with accelerating the good

of the feeding goods overhanding on the conveyor. This is depending from the typ of the conveyor and therefore highly sophisticated, because the sorting system can only handle, what the in-feed provides, with respect to the system performance. The main challenges of the in-feed process can be identified as:

- different speeds of sorter in in-feed
- a speed-component lateral to the component in sorter direction (v_s in Fig. 10)
- high performance of sorting process (with i.e. 15.000 sortations per hour) and therefore high accuracy for the in-feed at high speed-levels.

The core element of the in-feed is a flat or round belt – the in-feed-conveyor –, which carries, transports and accelerates the piece good. Geometrical and dynamic parameters are matter to variation. So this belt is the main object of further modelling within various CAE-approaches as following.

3. CAE

CAE is not only dynamics simulation with multibody dynamics (MBD), but a very large field of different approaches, modelling physical behavior with a set of describing equations and their numerical solution. The main domains of CAE in engineering are shown in Fig. 5 and can be found within [5].

All of them can be represented in different software domains, like signal-flow-oriented systems (MATLAB/Simulink) or graphical library-based systems.

All further comments refer to MBD-Systems. The great difference is in how one has to build the model, with one time deriving all governing equations exactly and bringing them to a numerical (or very rare analytical) solution. The other time powerful software-tools like MSC.ADAMS, ITI SimX, RecurDyn, Simpack or CAD-integrated CAE-tools in all major CAD-systems enable a very easy way to model basic behavior. Herein a spring looks like a spring and has two “physical connectors” in difference to its governing equation, which powers the object in behind.

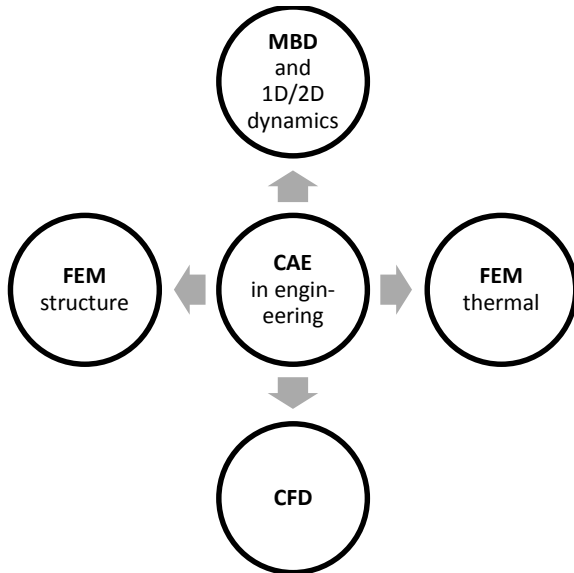

Fig. 5. CAE domains in mechanical engineering (and logistics engineering)

3.1 MBD modelling for conveyor belt drives

The in-feed-conveyor is normally a belt drive with two pulleys and tensioning device (Fig. 4). Much theoretical work has been done analytically and in respect to belt materials, to ensure a secure function [10]. The belt drive modelling in MBD and the main commercial systems therein is until now limited to traction belts where conveying is no matter. Special toolkits (Fig. 6) are commercial products to model dynamic load history for stress and fatigue analysis as well as belt dynamics with respect to pulley/belt design, some more sophisticated methods for tension-member drives – in parallel to FEM-technologies – are in development i.e. for MSC.ADAMS [13].

These “drives” are modelled by transfer functions between all included parts and have no possibility, to act as a conveyor, as they only transfer dynamic parameters (moments, angular speeds,...) from one pulley to the other.

The in-feed-conveyor now has to carry loads on its tension member on the carriage side with interaction between the load and the belt via normal and friction forces. Because the SLAKE isn’t important the following modelling is suggested, to model belt conveyors in logistics:

- a rigid body represents the carriage side of the conveyor
- this conveyor is driven by an outer control via powering moment or dynamic constraints
- the contact to the piece good is established via
 - 3D-geometry-based-contacts (details in [6])
 - Characteristic points of contact, represented in CAD-geometry, to avoid plane surface/surface contact which is numerically unstable; reducing the parcel surface to “ideal” contact points.
- these contacts are activated/deactivated selectively, controlled by position measurement, to
 - discharge the good from the conveyor
 - overhand to another conveyor
 - Note: the conveyor itself has not any contact to other bodies, beside the carrying goods.

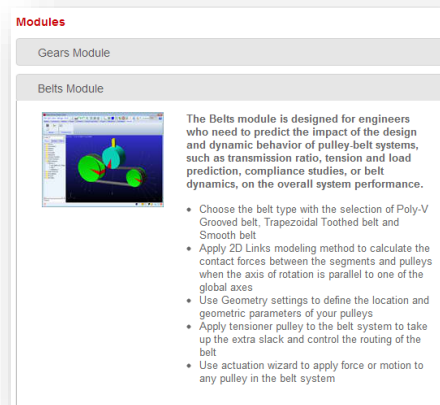

Fig. 6. Factsheet of MSC.ADAMS/Machinery – Beltdrive [4]

So in case of the in-feed, two rigid bodies are intersecting each other with no contact in between (Fig. 7). The piece good is transferred from one conveyor to the other by selectively (de)activating contacts. This procedure makes much effort in modelling, but is by state of the art of simulation tools the only way to model the conveyor. Another approach, via flexible or incremental belt bodies has been chosen but withdrawn because of modelling effort and computation time.

4. Modelling of the in-feed

Besides there are some necessary adaptations for modelling belt drives in MBD from 3.1, there is another big challenge to implement: the piece good and its contact description to the conveyor.

Therefore one has to take a very detailed look at contact formulation, which can be found in [6] to get performing simulations. As in case of the conveyor-piece good contact brings two plane surfaces together. There is one main aspect to consider. Two plane surfaces don’t have a unique solution to define contact points, which is what the typical contact-statements in MBD expect. So the following approach has been chosen.

4.1 MSC.ADAMS - MBD approach 3D

Modelling the piece good-conveyor interaction via i.e. the MSC.ADAMS CONTACT statement [4] it was necessary, to provide at least one uneven surface via CAD-geometry – what the parcel or the conveyor is in real! Thus the parcel got i.e. nine half-spheres at governing positions, to force contact points and tracks therein (Fig. 7) – contact regions, theory in [3]. Using a non uniform distribution of mass inside the parcel, a real world contact is simulated the better, the more half-spheres are modelled. This is in direct conflict with underlying modelling effort and simulation duration, where the number of nine contact regions could be identified as sufficient, also in respect to the analytical approach, which can consider ideal plain surface/surface contact (chap. 4.2) to validate the discrete approach via half-spheres.

Modelling the conveyor the approach from 3.1 was chosen and combined with the piece good-contact.

The overall MSC.ADAMS MBD simulation of the in-feed process is depicted in Fig. 7 with:

- Two rigid bodies representing the conveyors (Chap. 3.1)
- The in-feed of the parcel with discrete contact formulation (Chap. 4.1)
- A nonlinear contact statement at each half-sphere contact region [6], modelling a nonlinear visco-elastic material behavior of i.e. carton-rubber or softer or harder contacts depending on carried goods and belts.

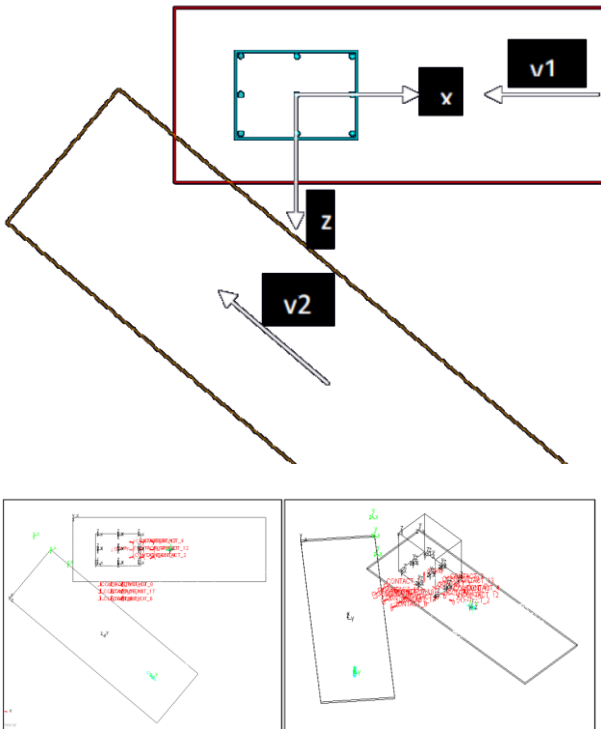

Fig. 7. in-feed with the conveyor- model from 3.1, and the conveyor-piece good contact from 4.1 with characteristic points of contact, represented in CAD-geometry

Thus the model is performing, it was used to analyze various scenarios with special respect to dynamic behavior and size of contact forces of the in-fed goods (Fig. 9, 10, 11).

4.2 2D-MBD (Modeling)

A way to avoid problems caused by full 3D contact formulations mentioned before is to use a reduced 2D representation [11]. That means the parcel cannot lift off from the conveyor. This assumption allows a relative simple description of the feed-in process.

By separating the contact surface (Fig. 8) into a certain number of square elements, the base for further numerical implementations is created. The single elements are denoted by the indices i (direction η) and j (direction ξ). The size of ge is affecting the accuracy of the simulation results and the calculating time. The normal forces N_{ij} and the friction forces R_{ij} are applied at the midpoint of each element.

For implementing static and dynamic friction in the MBD-Model a velocity proportional definition of the friction coefficient μ is selected (STEP-function [6]).

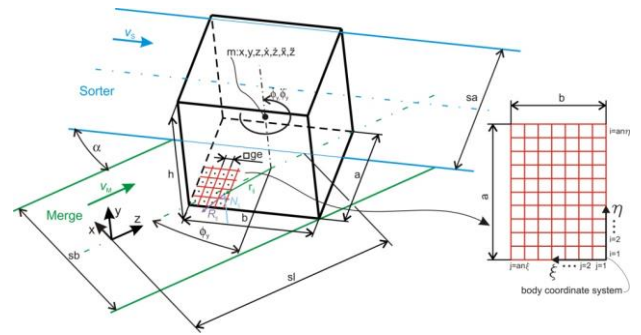

Fig. 8. 2D - MBD-Model

The differential equations to calculate center of gravity accelerations are obtained by the use of Newton's second law

$$\ddot{x} = \frac{R_x}{m} \quad \ddot{z} = \frac{R_z}{m} \quad \ddot{\phi}_y = \frac{M_y}{J_y} \quad (1)$$

The entire friction force R is calculated by adding all single element friction forces R_{ij} . The summation of the single element friction forces follows:

$$R_x = \sum_{i=1}^{anh} \sum_{j=1}^{anx} R_{xij} \quad R_z = \sum_{i=1}^{anh} \sum_{j=1}^{anx} R_{zij} \quad (2)$$

The moment M_y , which is caused by friction forces R_{ij} , is obtained analogical:

$$\begin{bmatrix} r_{xij} \\ 0 \\ r_{zij} \end{bmatrix} \times \begin{bmatrix} R_{xij} \\ 0 \\ R_{zij} \end{bmatrix} = \begin{bmatrix} 0 \\ M_{yij} \\ 0 \end{bmatrix}; \quad M_y = \sum_{i=1}^{anh} \sum_{j=1}^{anx} M_{yij} \quad (3)$$

The absolute and relative velocities for each element midpoint, necessary for evaluating the friction forces, are:

$$\begin{bmatrix} \dot{x} \\ 0 \\ \dot{z} \end{bmatrix} + \begin{bmatrix} 0 \\ \dot{\phi}_y \\ 0 \end{bmatrix} \times \begin{bmatrix} r_{xij} \\ 0 \\ r_{zij} \end{bmatrix} = \begin{bmatrix} v_{xij} \\ 0 \\ v_{zij} \end{bmatrix}; \tag{4}$$

$$\begin{bmatrix} v_{xij} \\ 0 \\ v_{zij} \end{bmatrix} - \begin{bmatrix} v_{Mx} \\ 0 \\ v_{Mz} \end{bmatrix} = \begin{bmatrix} v_{rxij} \\ 0 \\ v_{rzij} \end{bmatrix} \text{ or } \begin{bmatrix} v_{xij} \\ 0 \\ v_{zij} \end{bmatrix} - \begin{bmatrix} v_{Sx} \\ 0 \\ v_{Sz} \end{bmatrix} = \begin{bmatrix} v_{rxij} \\ 0 \\ v_{rzij} \end{bmatrix} \tag{5}$$

Using the Coulomb friction model (friction coefficient μ_{ij}), the element friction forces R_{ij} are read as follows:

$$\begin{bmatrix} R_{xij} \\ 0 \\ R_{zij} \end{bmatrix} = N_{ij} \cdot \mu_{ij} \left(\sqrt{v_{rxij}^2 + v_{rzij}^2} \right) \cdot \begin{bmatrix} -v_{rxij} \\ 0 \\ -v_{rzij} \end{bmatrix} \cdot \frac{1}{\sqrt{v_{rxij}^2 + v_{rzij}^2}} \tag{6}$$

The advantages of the 2D - model are:

- proper numerical handling (important for computational implementations)
- high accuracy of results (realistic implementation of friction effects)
- it is possible to consider roller conveyors or other belt configurations
- extendable for non- block shaped packets
- implementation of non-constant surface pressure distributions between packet and belt possible

4.3 Numerical Implementation and results

The software to simulate the merging procedure is written in MATLAB Fig. 9 shows the GUI of the program. There are different options for simulating belt conveyors, roll conveyors and strip merges [12].

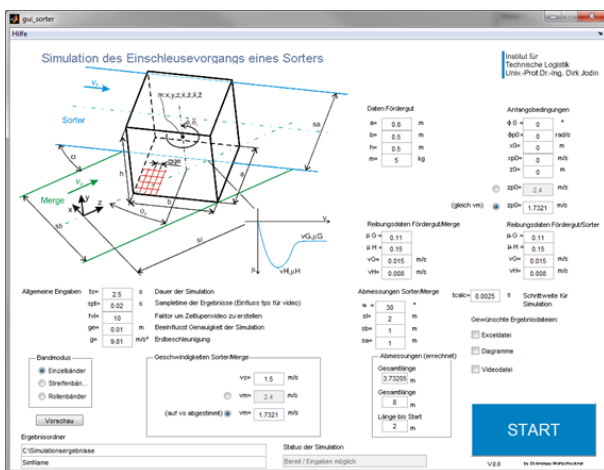

Fig. 9. GUI of the 2D-approach for the in-feed

Output of the program are all relevant data for analysing the motion process during feed-in. For that reason packet position and velocity are evaluated. Friction forces and friction moments are crucial for understanding the merging procedure. They are calculated for every time

step. (fig. 11). Fig. 10 illustrates the flow diagram of the program and the trace curves of a parcel during the feed-in process evaluated by the software.

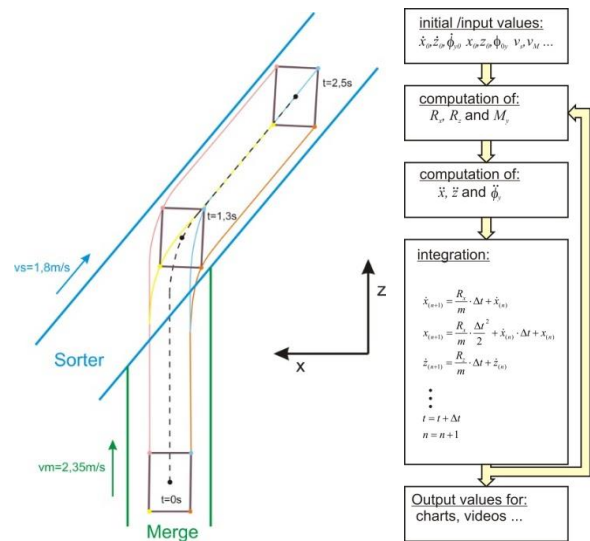
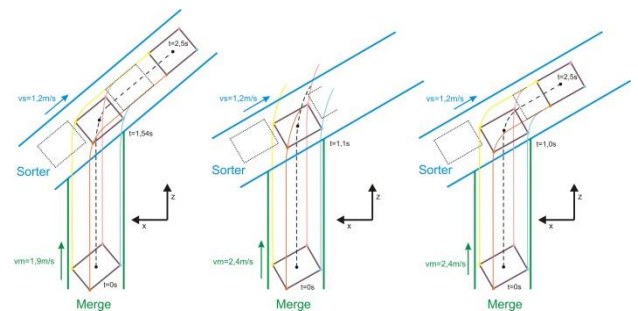

Fig. 10. Flow diagram and trace curves of the feed-in process

The software allows engineers a fast and safe dimensioning process of merges. Fig.11 shows specific results and for instance the variation of friction coefficients for a precise performing feed-in process. All this can be used to shorten development times by virtual testing and Design of Experiments (DoE).



Angle sorter/merge:	Angle sorter/merge:	Angle sorter/merge:
50°	60°	60°
$v_S = 1.2 \text{ m/s}$	$v_S = 1.2 \text{ m/s}$	$v_S = 1.2 \text{ m/s}$
$v_M = 1.9 \text{ m/s}$	$v_M = 2.4 \text{ m/s}$	$v_M = 2.4 \text{ m/s}$
$\mu_d = 0.25; \mu_s = 0.30$	$\mu_d = 0.25; \mu_s = 0.30$	$\mu_d = 0.50; \mu_s = 0.55$

Fig. 11. Influence of friction coefficient on feed-in

4.4 validation – selected results

As the 2D and the 3D model represent the same physical behavior but with slightly different modelling, taking different aspects into account, the results can be compared selectively and the models used for different depths and interests in investigation (see chap. 5).

Interesting results for system performance as well as for validation are:

- Friction forces good-conveyor: to examine the behavior and possible damage to the piece goods
- Speeds of in-feeding goods: to secure exact matching the pre-defined in-feed position/orientation on the main conveyor for high performance operation of the sorting system.

Herein the smaller the distance between in-fed goods becomes the higher the sorting performance will be. The main constraint for safe in-feed can be stated with:

$$v_s = \frac{v_M}{\cos(\alpha)} \quad (7)$$

With v_s sorter main conveyor speed and v_m merge speed with α as angle between sorter and merge. Therein all dynamic effects from friction and mass have influence on a non constant v_m during overlapping to v_s .

Now figure 9 shows the friction forces (R_x, R_z in x and z direction) and speeds of the two different models over time for validation.

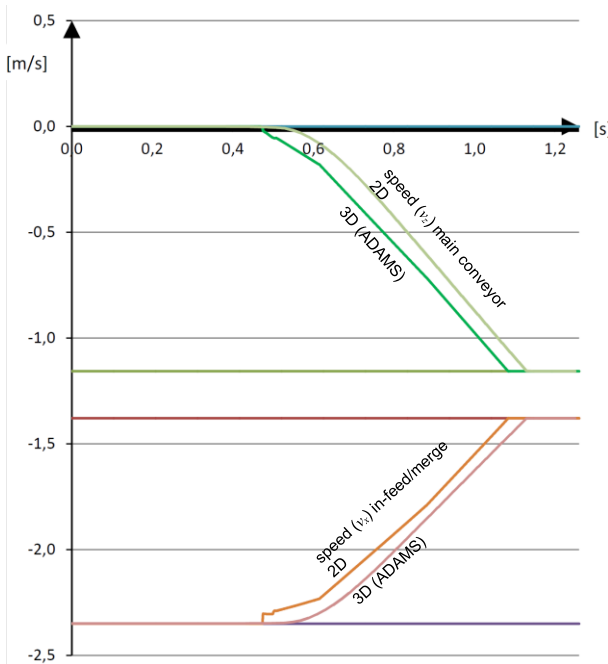
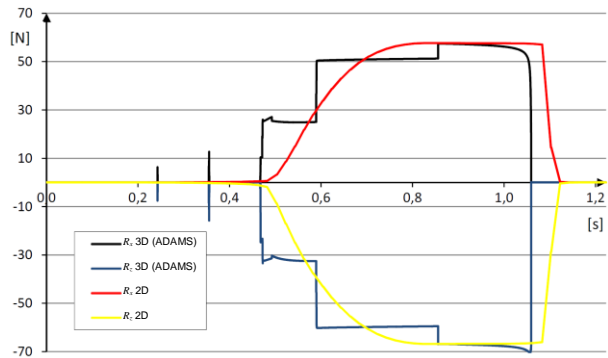

Fig. 9. in-feed with the 2D and 3D in-feed model. Friction forces and speeds in x and z direction.

The speeds of the in-fed goods show quite equal behavior as promised in prior work [11].

With those two different approaches for modelling the in-feed performing the same quality of results in the defined scope of interest, the two models can be used selectively for different tasks in investigation to maximize the simulation performance in respect to:

- computation time and accuracy
- necessary effort in adaption of parameters and geometries
- more global scenarios with connecting the in-feed to other simulation models (i.e. roller-conveyor, sorting mechanisms,...)

Friction forces match from both models with the following findings:

- The ADAMS (3D) model behaves more “discrete” because of switching on contacts selectively.
- It also shows some spikes, resulting from the representation over only four contact points, where the 2D model uses a much higher discretization of the surface-surface contact.
- The time behavior and the overall friction force work is equal.

5. Comparison of 2D and 3D approach of the in-feed process

Chapter five now works out the differences in modelling as an overview in table 1, to provide insights in how to use which approach in case of modelling the in-feed and similar modelling tasks in material handling simulation of piece goods. It shows how to optimize the in-feed by the use of the 2D and 3D models.

Table 1
Overview of potentialities and parameter ranges within the 2D and 3D model

category		2D	3D (ADAMS)
modeling	equations of motion	explicit	implicit
	geometries	idealized	real CAD
	contacts	various formulations	see CONTACT statement [6]
	effort	high	medium/high
	duration	very fast	fast
	adaptivity	low	very high
modell parameters	expand-ability	partial	full
	masses	freely adjustable	
	load distribution	partially variable	full flexibility/interconnection
	speed	freely adjustable	
	feeding angle	freely adjustable	
	friction	dependency of sliding speed (no stiction: CONTACT statement)	
solving	contact	Idealized (coulomb friction only)	only within CONTACT
	software	math. or numerical tool (Simulink)	various MBD commercial and free tools
	numerical method	free	predefined solver and robust
	duration	very fast	fast
autom. performance (DoE)	only by user written routines	built in	

post processing	visualization (video)	only by user written routines, additional effort	within package
	quick check and proof of concept	possible, additional effort	easily by assessment of visualization
	graphs	built in	
in-feed process	one parcel	possible	
	> one parcel	not appropriate	possible
	interaction with further machinery (parcels)	hardly implementable	all possibilities
	impacts overhanding to/from conveyors	hardly implementable	all possibilities
	detailed forces on goods	hardly implementable	possible, even stress recovery.
	discrete events (dumping)	impossible	possible
	quality/accuracy of results	mainly depending on discretization of contact surface	
	further in-feed technologies (rollers, ...)	reduced models (via analytical approaches)	all MBD functionality available

Using the 2D and 3D model adequately makes the in-feed process better performing in real scenarios, as certain exotic variations and combinations of parameters could have never investigated on real test-stands as well as the number of overall simulation runs and scenarios has been much higher in the virtual world. So this paper contributes to make engineering tasks in material handling development more “state of the art”, which is a declared mission of the Institute of Logistics Engineering in Graz.

6. Summary

This paper compares two different approaches in modelling the highly dynamic process of the in-feed, wherein both methodologies show results accordingly. An overview of possibilities in general use of these methods concludes the paper.

Ongoing and further research at the Institute of Logistics Engineering will provide a “conveyor-toolbox” within CAE for common material handling technology. This box can be used to build CAE – models in short time, with high accuracy by basing on submodules. As a concluding step it’s planned to replace or minimize physical test-stands by only performing CAE test runs.

REFERENCES

- [1] D. Jodin, M. ten Hompel, *Sortier- und Verteilsysteme, Grundlagen, Aufbau, Berechnung und Realisierung*, Springer, Berlin Heidelberg New York, 2012.
- [2] W. J. C. Verhagen, P. Bermell-Garcia, R. E. C. van Dijk, R. Curran, *A critical review of Knowledge-Based Engineering: An identification of research challenges*, Advanced Engineering Informatics, Vol. 26, Issue 1, 2011, pp. 5-15
- [3] W. Sextro, *Dynamical contact problems with friction*, Springer, Berlin Heidelberg, 2002.
- [4] msc.software, *Adams/Machinery*, available at: <http://www.mscsoftware.com/product/adam-smachinery/>, accessed: 2013-05-14.
- [5] S. Vajna, Chr. Weber, H. Bley, K. Zeman, *CAX für Ingenieure – Eine praxisbezogene Einführung*, Springer, Berlin Heidelberg, 2009.
- [6] C. Landschuetzer, M. Fritz, D. Jodin, *Knowledge based engineering and modern CAE for sorting systems*, Proceedings in Manufacturing Systems, Vol. 7, Issue 1, 2012, pp. 69-76.
- [7] F. Rieg, R. Steinhilper, *Handbuch Konstruktion*, Haner, München, Wien, 2012.
- [8] K.-H. Grote, E. K. Antonsson, *Springer Handbook of Mechanical Engineering*, Springer, Heidelberg, 2008.
- [9] G. Pahl, W. Beitz, J. Feldhusen, K.H. Grote, *Konstruktionslehre – Grundlagen erfolgreicher Produktentwicklung Methoden und Anwendung*, Springer, Berlin Heidelberg New York, 2007.
- [10] G. Gerbert: *Traction Belt Mechanics*, Sweden, 1999.
- [11] D. Jodin, A. Wolfschluckner, *Merge problems with high speed sorters*, Progress in Material Handling Research: 2010, Charlotte, NC, USA, 2010, pp. 186-196.
- [12] transnorm Europe, *Angled-Belt Conveyor*, available at: <http://www.transnorm.com/index.php?id=977/>, accessed: 2013-05-21.
- [13] MSC.Software, *Keynote at MSC.Software User Meeting 2013*, Berlin, 2013-05-13, 14.